

Current Mode PWM Controller

NCV12711



MSOP10, 3x3
CASE 846AE

The NCV12711 is a fixed-frequency peak-current-mode PWM controller containing all of the features necessary for implementing single-ended power converter topologies. The device operates from 4 V to 45 V without auxiliary winding and within its thermal capabilities. The controller contains a programmable oscillator capable of operating from 100 kHz to 1 MHz and integrates slope compensation to prevent subharmonic oscillations. The controller includes a programmable soft-start, input voltage UVLO protection, and an over-power protection (OPP) circuit which limits the total power capability of the circuit as the input voltage increases. The UVLO pin also features a shutdown comparator which allows for an external signal to disable switching and brings the controller into a low quiescent state. An onboard op-amp allows the implementation of primary-side regulated converters or non-isolated dc-dc converters.

The NCV12711 contains a suite of protection features including cycle-by-cycle peak-current limiting with smooth frequency increase and a timer-based overload protection. All protection features place the device into a low quiescent fault mode with a 1-s auto-recovery period to allow for system recovery if the fault condition is removed.

Common General Features

- Wide V_{cc} Input Range (4 – 45 V)
- Internal 7.5-V Regulator
- Current-Mode Control with Adjustable Slope Compensation
- 0% Duty Ratio Operation in No-Load Condition
- Internal Over Power Protection
- Single Resistor Programmable Oscillator – 100 kHz to 1 MHz
- Adjustable Soft-Start on Peak Current and Frequency
- Programmable Input Voltage UVLO with Hysteresis
- Shutdown Threshold for External Disable
- Overload Protection with 30 ms Overload Timer
- Internal Operational Amplifier
- Fault Auto-recovery Mode with 1-s Auto-recovery Period
- ± 1 A Source / Sink Gate Driver
- NCV Prefix for Automotive and Other Applications Requiring Unique Site and Control Change Requirements; AEC-Q101 Qualified and PPAP Capable

Typical Applications

- Single-ended Flyback and Forward Converters for Electric Vehicles
- Automotive 4 – 45 V Input DC/DC Controller for Auxiliary Power

MARKING DIAGRAM

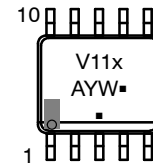

- V11x = Specific Device Code
 x = A
 A = Assembly Location
 Y = Year
 W = Work Week
 ■ = Pb-Free Package

PIN CONNECTIONS

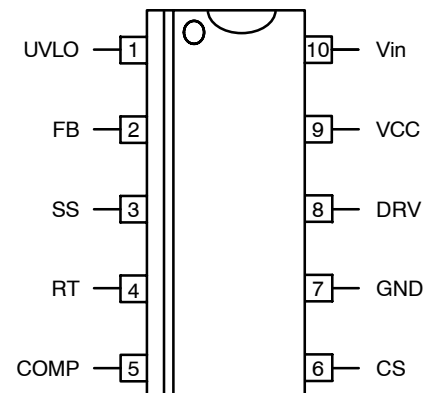

ORDERING INFORMATION

Device	Package	Shipping†
NCV12711ADNR2G	MSOP10, 3x3 (Pb-Free)	2,500 / Tape & Reel

†For information on tape and reel specifications, including part orientation and tape sizes, please refer to our Tape and Reel Packaging Specifications Brochure, BRD8011/D.

NCV12711

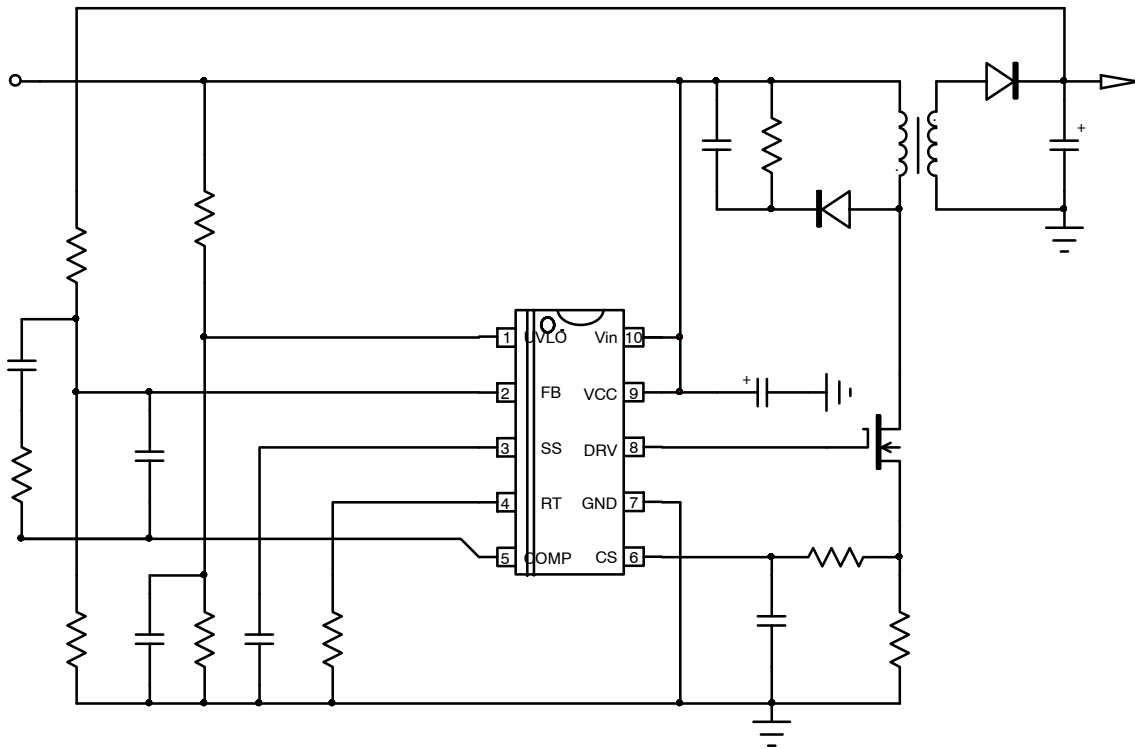

Figure 1. Low-Dissipation Wide-Range Application Non-Isolated Converter

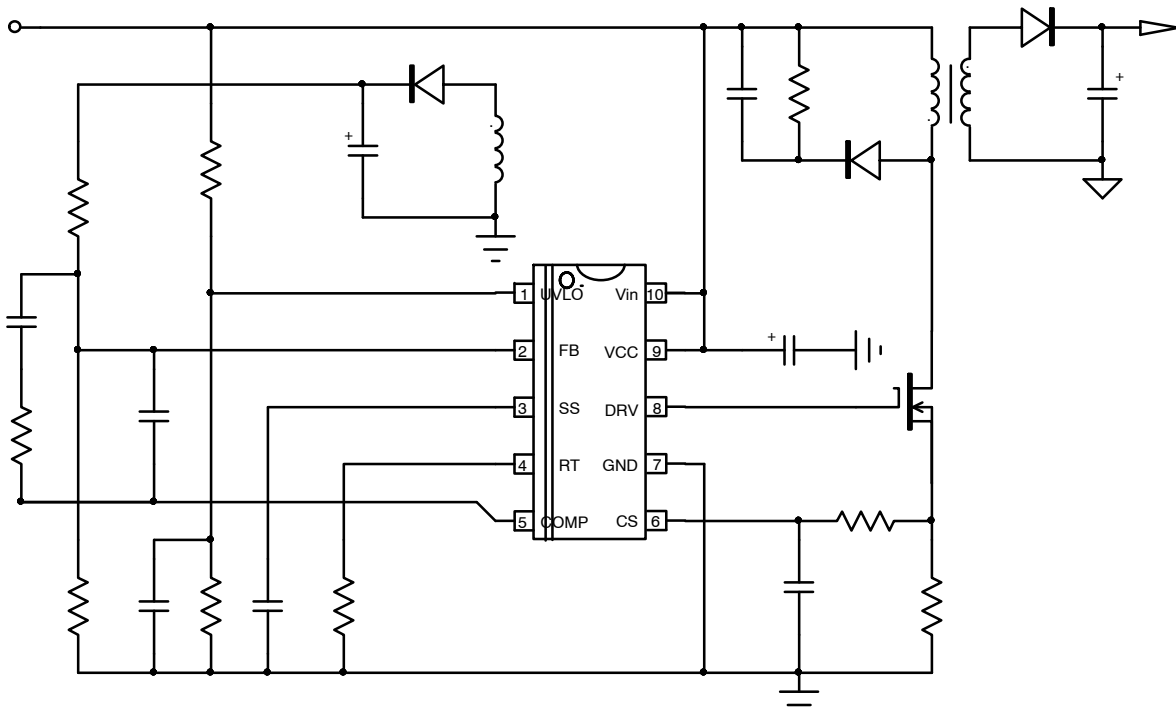

Figure 2. Primary-Side-Regulated Wide-Range Application Isolated Converter

NCV12711

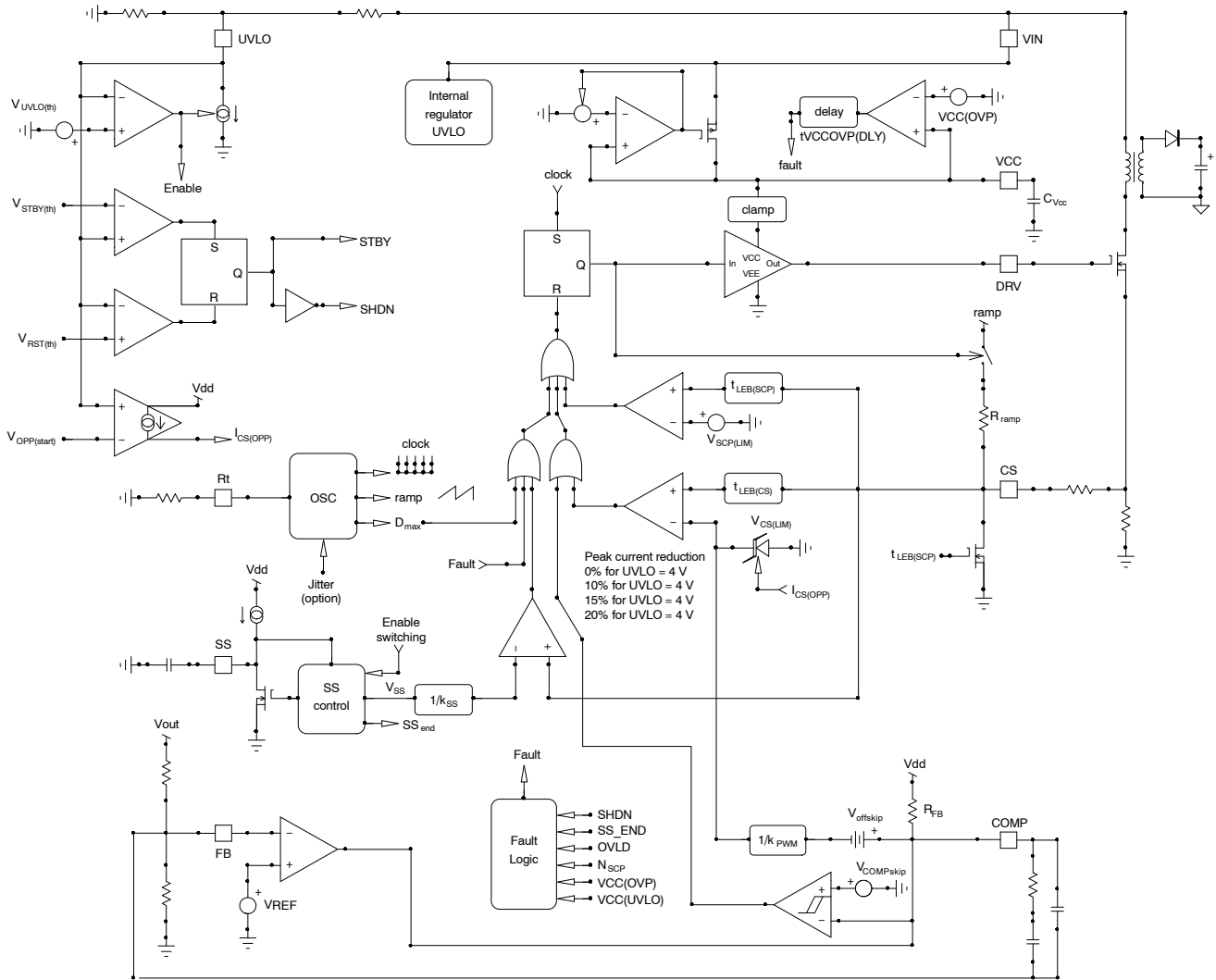

Figure 3. Block Diagram

NCV12711

PIN DESCRIPTION

DFNW10	Pin Name	Pin Description
1	UVLO	The UVLO pin is the input to the standby and UVLO comparators. A resistor divider between the power supply input voltage and ground is connected to the UVLO pin to set the input voltage level at which the controller will be enabled. UVLO hysteresis is set by a 5- μ A pull-down current source. An externally-supplied pull-down signal can also be used to disable the controller. The UVLO pin is also used to determine the over-power protection amount.
2	FB	The FB pin senses the voltage to be regulated via a resistive divider. A passive network connected between this pin and COMP allows to set poles and zeroes as suggested by the compensation strategy.
3	SS	A capacitor on this pin sets the soft-start sequence during which the peak current setpoint is gradually increased as well as the switching frequency.
4	RT	The RT pin sets the oscillator frequency in the controller. This pin requires a resistor to ground closely located to the controller. Typical R_T resistor values are in the range of 10 k Ω – 150 k Ω .
5	COMP	This is the op-amp output pin, loaded by the R_{FB} resistance.
6	CS	The CS pin is the current sense input for the PWM and current limit comparators. An external low-pass filter is recommended for improved noise immunity. The external filter resistor is also used to determine the amount of compensation ramp added to the current sense information.
7	GND	This pin is the controller ground.
8	DRV	The DRV pin is a high current output used to drive the external MOSFET gate. DRV has source and sink capability of 1 A.
9	VCC	The VCC pin provides bias to the controller via a linear regulator. An external decoupling capacitor to ground in the range of 1 – 10 μ F is recommended. An auxiliary winding can help turn off the regulator and improve power dissipation in wide input range applications.
10	VIN	This is the controller supply input. If kept below $V_{CC(OVP)}$ it can be safely connected to VCC.

MAXIMUM RATINGS

Symbol	Rating	Value	Unit
$V_{in(MAX)}$	Supply Voltage (Continuous)	-0.3 to 45	V
$I_{CC(MAX)}$	Supply Current $V_{in} = 12$ V $V_{in} = 45$ V	35 10	mA
$V_{CC(MAX)}$	VCC pin	-0.3 to 30	V
$V_{DRV(MAX)}$	DRV Voltage (Note 1)	-0.3 V to $V_{DRV(high)}$	V
$I_{DRV(MAX)}$	DRV Current (Peak)	1.25	A
$V_{SIG(MAX)}$	Max Voltage on Signal Pins $V_{VCC} > 5.5$ V $V_{VCC} < 5.5$ V	-0.3 to 5.5 -0.3 to V_{VCC}	V
$I_{SIG(MAX)}$	Max Current on Signal Pins	10	mA
$R_{\theta J-A}$	Thermal Resistance Junction-to-Air	139	$^{\circ}$ C/W
$\Psi_{\theta J-T}$	Junction-to-Top Thermal Characterization Parameter	5.5	$^{\circ}$ C/W
$\Psi_{\theta J-B}$	Junction-to-Board Thermal Characterization Parameter	68.4	$^{\circ}$ C/W
T_{JMAX}	Maximum Junction Temperature	150	$^{\circ}$ C
T_{STG}	Storage Temperature Range	-55 to 150	$^{\circ}$ C
T_J	Operating Temperature Range	-40 to 125	$^{\circ}$ C
	ESD Capability (Notes 2, 3) Human Body Model per JEDEC Standard JESD22-A114E. Charge Device Model per JEDEC Standard JESD22-C101E.	2000 1000	V

Stresses exceeding those listed in the Maximum Ratings table may damage the device. If any of these limits are exceeded, device functionality should not be assumed, damage may occur and reliability may be affected.

- Maximum driver voltage is limited by the driver clamp voltage, $V_{DRV(high)}$, when V_{CC} exceeds the driver clamp voltage. Otherwise, the maximum driver voltage is V_{CC} .
- This device series contains ESD protection and exceeds the following tests:
Human Body Model 2000 V per JEDEC Standard JESD22-A114E
Charge Device Model 1000 V per JEDEC Standard JESD22-C101E
- This device contains latch-up protection and has been tested per JEDEC JESD78D, Class I and exceeds ± 100 mA.

RECOMMENDED OPERATING CONDITIONS

Symbol	Rating	Value	Unit
V _{in}	Supply Voltage	4.5 – 40	V
T _J	Operating Temperature Range	–40 to 125	°C

Functional operation above the stresses listed in the Recommended Operating Ranges is not implied. Extended exposure to stresses beyond the Recommended Operating Ranges limits may affect device reliability.

ELECTRICAL CHARACTERISTICS (V_{IN} = 12 V, V_{CC} = 12 V, V_{COMP} = open, C_{DRV} = 1 nF, R_T = 53.6 kΩ, V_{CS} = 0 V, V_{SS} = Open, V_{UVLO} = 1.2 V, V_{FB} = 0 V, for typical values T_J = 25°C, for min/max values, T_J is –40°C to 125°C, unless otherwise noted)

Symbol	Characteristics	Test Condition	Min	Typ	Max	Unit
--------	-----------------	----------------	-----	-----	-----	------

SUPPLY CIRCUIT

V _{CC(reg)}	Supply Voltage V _{CC} Regulation Level	I _{CC} = –5 mA	7.0	7.5	8.0	V
V _{in(STR)}	Start-up Level (Part Switches)	V _{in} increasing	3.5	3.7	3.95	V
V _{in(MIN)}	Minimum Operating Voltage	V _{in} decreasing	3.3	3.5	3.75	V
V _{CC(reset)}	Reset Voltage (All Faults Clear)	V _{CC} decreasing	3.0	3.3	3.6	V
V _{IN(hys)}	Hysteresis between V _{in(STR)} and V _{in(MIN)}		–	200	–	mV
I _{start}	Start-up Current	V _{CC} = V _{CC(reg)} – 0.2 V	15	20	–	mA
I _{VIN(LIM)}	Start-up Current with V _{CC} = 0 V	V _{CC} pin shorted to ground	–	2.5	–	mA
V _{CC(SC)}	V _{CC} Threshold for Non-Short Circuit Detection		–	0.2	–	V
I _{Vin(off)}	Start-up Circuit Off-State Leakage Current	V _{in} = 45 V	–	–	95	μA
V _{CC(OVP)}	Supply Over-Voltage Protection		25	27	29	V
V _{CC(OVP_HYS)}	Hysteresis on Supply OVP		–	100	–	mV
t _{VCCOVP(DLY)}	VCC OVP Detection Filter Delay		–	7	–	μs
I _{CC(SHDN)}	Supply Current SHDN (VCC Pin)	V _{UVLO} = 0 V	–	60	120	μA
I _{CC(STBY)}	STBY (VCC Pin)	V _{UVLO} = 0.4 V	–	340	650	μA
I _{CC(SHDNVI)}	SHDN (VIN and VCC Pins Shorted)	V _{UVLO} = 0 V	–	104	170	μA
I _{CC(STBYVI)}	STBY (VIN and VCC Pins Shorted)	V _{UVLO} = 0.4 V	–	380	700	μA
I _{CC(EN)}	Enable	C _{DRV} = Open, V _{COMP} = 2 V	–	–	4	mA
I _{CC(FLT)}	Fault	V _{CS} = 0 V	–	–	500	μA

CURRENT SENSE

V _{CS(LIM)}	Current Limit Comparator Threshold		237	250	263	mV
t _{CS(DLY)}	Propagation Delay From Current Sense Limit to DRV Low	Step V _{CS} from 0 – 0.35 V	–	25	75	ns
V _{SCP(LIM)}	Short Circuit Protection (SCP) Current Limit Threshold		–	325	–	mV
t _{SCP(DLY)}	Propagation Delay From Short Circuit Limit to DRV Low	Step V _{CS} from 0 – 0.44 V	–	25	75	ns
t _{on,min}	Minimum On-time Duration		–	135	170	ns
N _{SCP}	Short Circuit Counter	V _{CS} = 1 V	–	4	–	
t _{LEB(CS)}	CS Leading Edge Blanking (LEB)		60	110	155	ns
t _{LEB(SCP)}	SCP Leading Edge Blanking		35	60	90	ns
R _{PD(LEB)}	CS LEB Pull-down Resistance		–	27	55	Ω
t _{CS(OVLD)}	Overload Timer Duration	V _{CS} > 0.25 V	22.5	28.5	34.5	ms
V _{CS(skip)}	CS Skip Threshold in % of the Max CS Level	0% duty ratio – V _{COMP} < 325 mV	–	0	–	%
V _{ramp}	Compensation Ramp Peak Level		1.55	1.8	2.05	V
R _{ramp}	Internal Ramp Resistance to CS Pin		15	21	27	kΩ

NCV12711

ELECTRICAL CHARACTERISTICS ($V_{IN} = 12\text{ V}$, $V_{CC} = 12\text{ V}$, $V_{COMP} = \text{open}$, $C_{DRV} = 1\text{ nF}$, $R_T = 53.6\text{ k}\Omega$, $V_{CS} = 0\text{ V}$, $V_{SS} = \text{Open}$, $V_{UVLO} = 1.2\text{ V}$, $V_{FB} = 0\text{ V}$, for typical values $T_J = 25^\circ\text{C}$, for min/max values, T_J is -40°C to 125°C , unless otherwise noted) (continued)

Symbol	Characteristics	Test Condition	Min	Typ	Max	Unit
--------	-----------------	----------------	-----	-----	-----	------

COMP SECTION

K_{PWM}	PWM to COMP Gain Through Resistor Divider	$V_{COMP} = 1.25\text{ V} / 2.9\text{ V}$	7.6	8.0	8.4	
$t_{PWM(Dly)}$	Propagation Delay to DRV Low (Note 6)	$V_{COMP} = 2\text{ V}$, Step $V_{CS} 0 - 0.35\text{ V}$	–	25	75	ns
$V_{offskip}$	Internal Feedback Offset		0.3	0.64	0.91	V
$V_{COMP(skip)}$	0% Duty Ratio Level – 0–A Setpoint and No DRV	V_{COMP} is decreasing	–	325	–	mV
$V_{COMP(skip_hys)}$	Voltage Hysteresis between Skip and Skip_out Level	V_{COMP} is increasing	–	5	–	mV
R_{FB}	Internal Pull-Up Resistance		4	5	6	k Ω
$V_{COMP(open)}$	COMP Open Pin Voltage	$V_{cc} = 3.6\text{ V}$	3.15	3.45	–	V
I_{COMP}	COMP Output Current	$V_{COMP} = 0$	0.84	1	1.2	mA
D_{MAX}	Maximum Duty Ratio Limit (Note 6)	$V_{COMP} = \text{Open}$	86	90	94	%
D_{MIN}	Minimum Duty Ratio (Note 6)	$V_{COMP} = 0$	–	–	0	%

OPERATIONAL AMPLIFIER SECTION

V_{ref}	Voltage Feedback Input	$T_J = 25^\circ\text{C}$ $-40^\circ\text{C} < T_J < 125^\circ\text{C}$	2.45 2.42	2.5 2.5	2.55 2.58	V
I_{IB}	Input Bias Current	$V_{FB} = 3\text{ V}$	–	0.01	–	μA
A_{OL}	Open-Loop Voltage Gain	$V_{COMP} = 2$ to 4 V	–	90	–	dB
BW	Unity Gain Bandwidth ($T_J = 25^\circ\text{C}$)		–	1	–	MHz
PSRR	Power Supply Rejection Ratio		–	60	–	dB
I_{OPS}	Output Current (Output Resistance is R_{FB}) Sink	$(V_{COMP} = 0.35\text{ V}, V_{FB} = 2.7\text{ V})$	–	10	–	mA
V_{OTH} V_{OTL}	Output Voltage Swing High State Low State	COMP is open, $V_{FB} = 2.3\text{ V}$ COMP is open, $V_{FB} = 2.7\text{ V}$	– –	4.8 0.03	– 0.15	V V

SOFT START

$V_{SS(open)}$	Soft-Start Open Pin Voltage	$V_{cc} = 3.6\text{ V}$	2.80	3.35	–	V
$V_{SS(end)}$	Soft-Start End Threshold		1.85	2.00	2.15	V
I_{SS}	Soft-Start Current	$0 < V_{SS} < V_{SS(end)}$	12	15	18	μA
K_{SS}	Soft-Start to CS Divider		–	8	–	
$R_{SS(DIS)}$	Soft-Start Discharge Resistance		–	–	100	Ω
$f_{SW(SS)}$	Minimum Frequency for $V_{SS} = 0\text{ V}$	Clamp frequency	20	30	–	kHz

OSCILLATOR

f_{OSC1}	Oscillator Frequency 1	$R_T = 53.6\text{ k}\Omega$	185	200	215	kHz
f_{OSC2}	Oscillator Frequency 2	$R_T = 130\text{ k}\Omega$	90	100	110	kHz
f_{OSC3}	Oscillator Frequency 3	$R_T = 18.7\text{ k}\Omega$	450	500	550	kHz
f_{OSC4}	Oscillator Frequency 4	$R_T = 8.66\text{ k}\Omega$	–	1000	–	kHz

UNDER-VOLTAGE LOCKOUT

$V_{STBY(th)}$	Standby Threshold	V_{UVLO} increasing	0.3	0.35	0.4	V
$V_{RST(th)}$	Reset Threshold	V_{UVLO} decreasing	0.25	0.3	0.35	V
$V_{STBY(HYS)}$	Standby Hysteresis	V_{UVLO} decreasing	–	50	–	mV
$t_{STBY(DLY)}$	Standby Detection RC Filter		–	7	–	μs
$V_{UVLO(th)}$	UVLO Threshold	V_{UVLO} increasing	0.49	0.5	0.51	V
$I_{UVLO(HYS)}$	UVLO Hysteresis Current		4.5	5	5.5	μA
$t_{UVLO(DLY)}$	UVLO Detection Delay Filter	$V_{UVLO} = V_{UVLO(th)} - 50\text{ mV}$	–	1.1	–	μs

NCV12711

ELECTRICAL CHARACTERISTICS ($V_{IN} = 12\text{ V}$, $V_{CC} = 12\text{ V}$, $V_{COMP} = \text{open}$, $C_{DRV} = 1\text{ nF}$, $R_T = 53.6\text{ k}\Omega$, $V_{CS} = 0\text{ V}$, $V_{SS} = \text{Open}$, $V_{UVLO} = 1.2\text{ V}$, $V_{FB} = 0\text{ V}$, for typical values $T_J = 25^\circ\text{C}$, for min/max values, T_J is -40°C to 125°C , unless otherwise noted) (continued)

Symbol	Characteristics	Test Condition	Min	Typ	Max	Unit
--------	-----------------	----------------	-----	-----	-----	------

UNDER-VOLTAGE LOCKOUT

$t_{UVLO(EN)}$	Enable Filter Delay	V_{UVLO} increasing	-	5	-	μs
----------------	---------------------	-----------------------	---	---	---	---------------

OVER-POWER PROTECTION

$V_{OPP(START)}$	UVLO Voltage Above Which OPP Applied		-	1		V
OPP_{red}	Maximum Peak Current Reduction	$V_{UVLO} = 4\text{ V}$	-	15	-	%
OPP_{clip}	Internal Peak Reduction Clamp on UVLO	$V_{CS} = V_{CS(LIM)} (1 - OPP_{red})$	-	4	-	V
$V_{OPP(0\%)}$	COMP Threshold Voltage Above Which OPP is Applied		-	1.4	-	V
$V_{OPP(100\%)}$	COMP Threshold Voltage for 100% OPP		-	2.6	-	V

GATE DRIVE

$t_{DRV(rise)}$	DRV Rise Time	$V_{DRV} = 1.2\text{ V to }10.8\text{ V}$, $C_{DRV} = 1\text{ nF}$	6	10	16	ns
$t_{DRV(fall)}$	DRV Fall Time	$V_{DRV} = 10.8\text{ V to }1.2\text{ V}$, $C_{DRV} = 1\text{ nF}$	6	10	16	ns
$I_{DRV(SRC)}$	DRV Source Current	$V_{DRV} = 6\text{ V}$, Note 8	-	0.9	-	A
$I_{DRV(SNK)}$	DRV Sink Current	$V_{DRV} = 6\text{ V}$, Note 8	-	1.0	-	A
$V_{DRV(clamp)}$	DRV Clamp Voltage	$V_{CC} = 20\text{ V}$, $R_{DRV} = 10\text{ k}\Omega$	8	10	12	V
$V_{DRV(MIN)}$	Minimum DRV Voltage	$V_{CC} = V_{CC(Reg)} + 100\text{ mV}$, $R_{DRV} = 10\text{ k}\Omega$	6	-	-	V

FAULT PROTECTION

t_{AR}	Auto-recovery Timer		0.8	1	1.2	s
----------	---------------------	--	-----	---	-----	---

THERMAL SHUTDOWN

T_{SHDN}	Thermal Shutdown		150	165	180	$^\circ\text{C}$
$T_{SHDN(hys)}$	Thermal Shutdown Hysteresis		-	25	-	$^\circ\text{C}$

Product parametric performance is indicated in the Electrical Characteristics for the listed test conditions, unless otherwise noted. Product performance may not be indicated by the Electrical Characteristics if operated under different conditions.

4. Disabling of overload timer refers to not acknowledging overload as a fault. The device will continue to switch indefinitely without going to fault mode.
5. Disabling Slope compensation means that no compensation ramp is applied.
6. Electrical characteristics apply to both COMP Architectures
7. OPP Current Gain disabled means that no OPP current is injected out of the CS pin
8. Guaranteed by design

TYPICAL CHARACTERISTICS

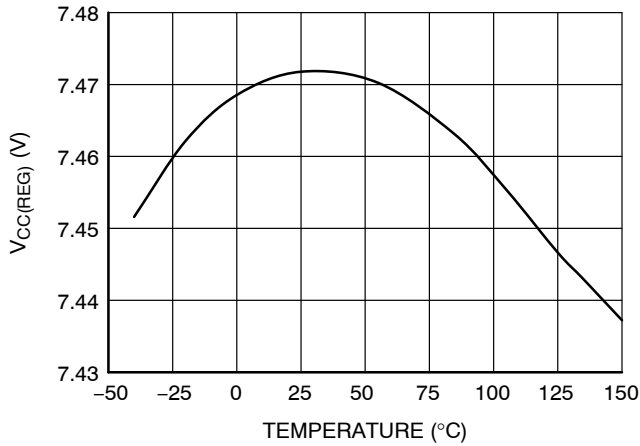

Figure 4. V_{CC(REG)} vs. Temperature

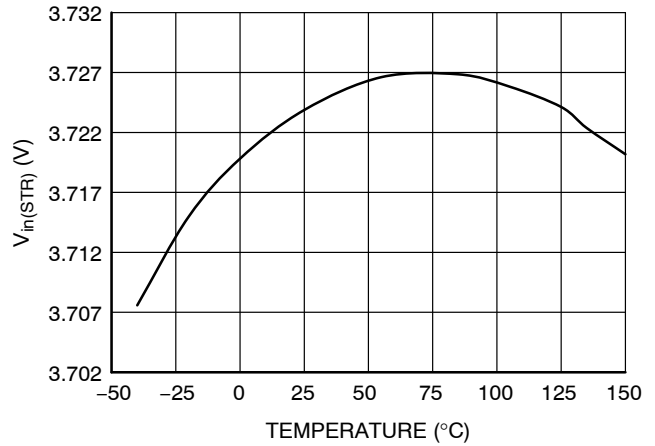

Figure 5. V_{in(STR)} vs. Temperature

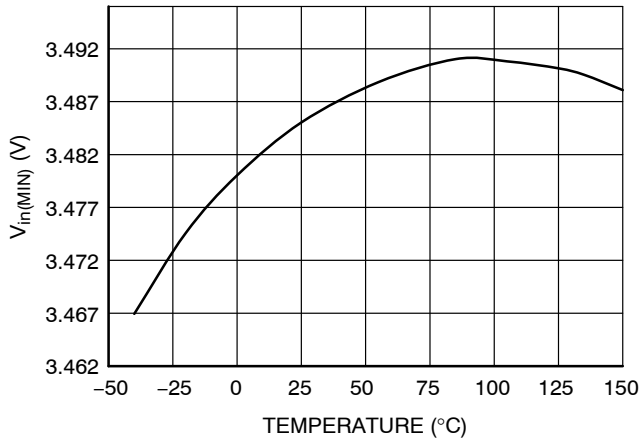

Figure 6. V_{in(MIN)} vs. Temperature

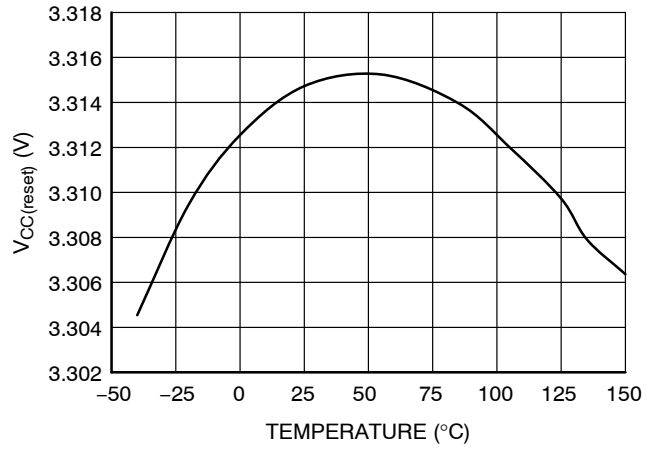

Figure 7. V_{CC(reset)} vs. Temperature

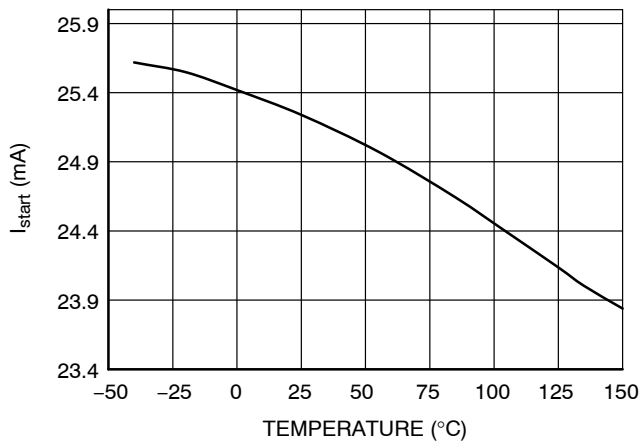

Figure 8. I_{start} vs. Temperature

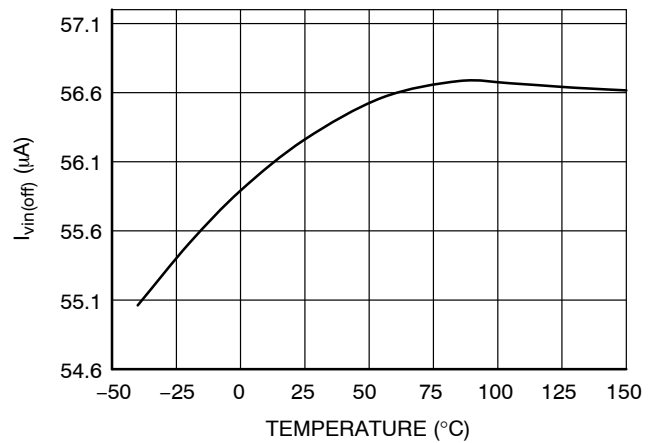

Figure 9. I_{vin(off)} vs. Temperature

TYPICAL CHARACTERISTICS (continued)

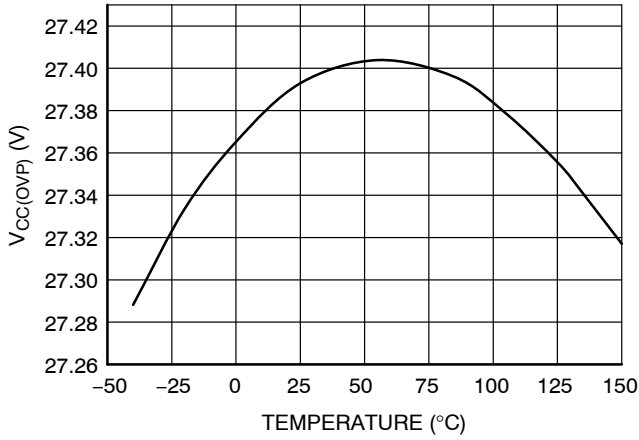

Figure 10. V_{CC(OVP)} vs. Temperature

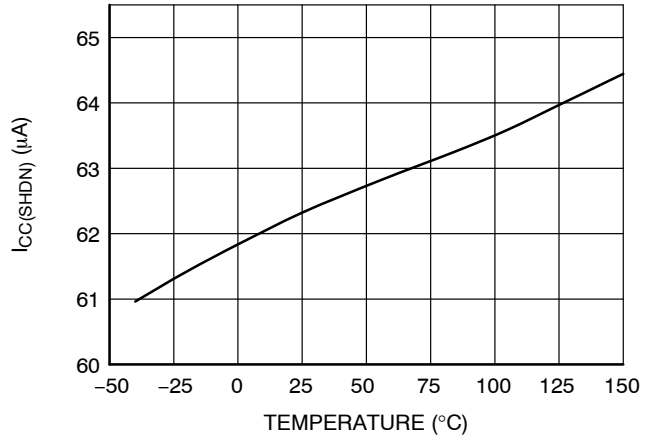

Figure 11. I_{CC(SHDN)} vs. Temperature

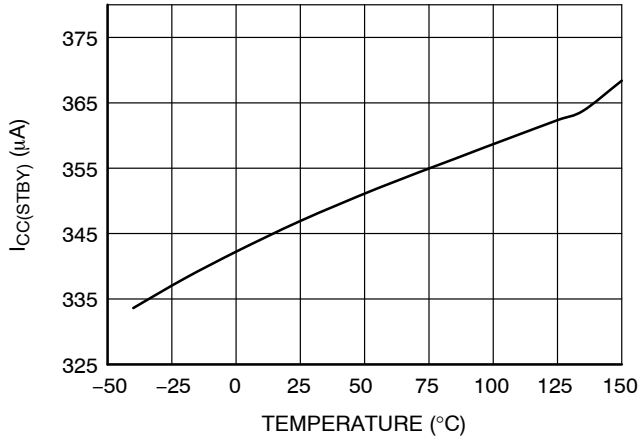

Figure 12. I_{CC(STBY)} vs. Temperature

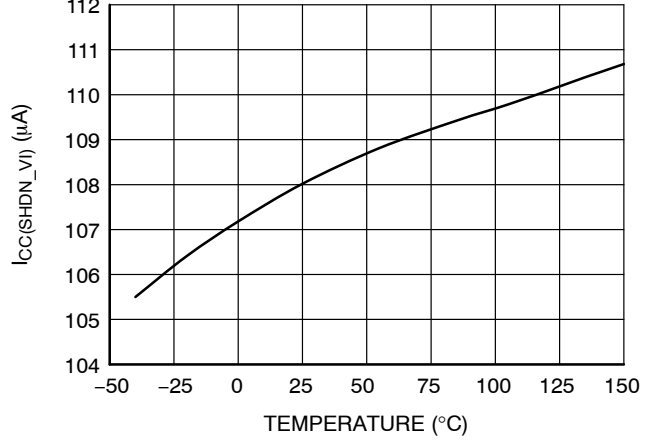

Figure 13. I_{CC(SHDN_VI)} vs. Temperature

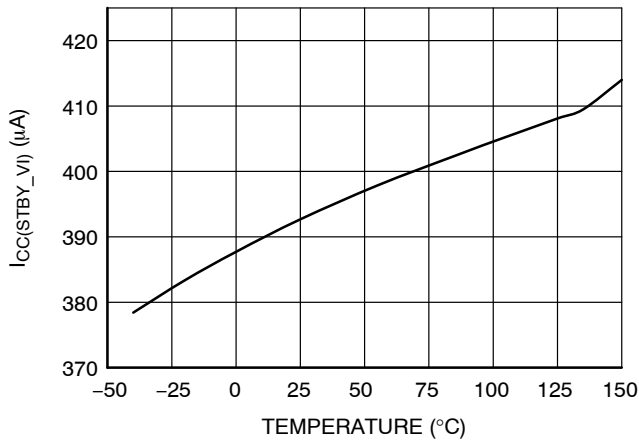

Figure 14. I_{CC(STBY_VI)} vs. Temperature

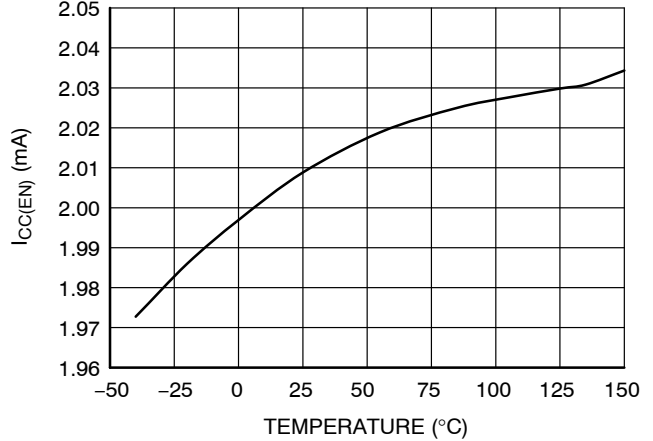

Figure 15. I_{CC(EN)} vs. Temperature

TYPICAL CHARACTERISTICS (continued)

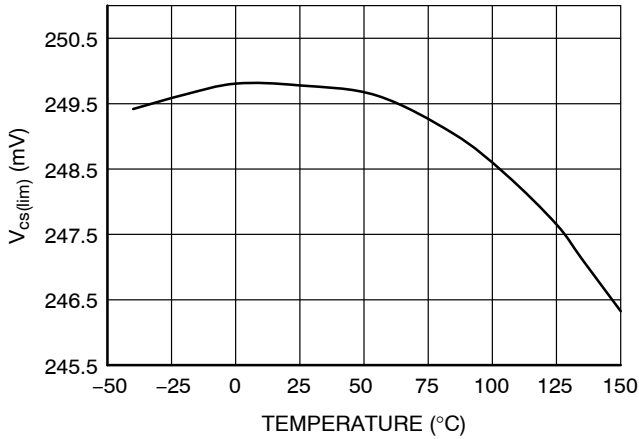

Figure 16. $V_{cs(lim)}$ vs. Temperature

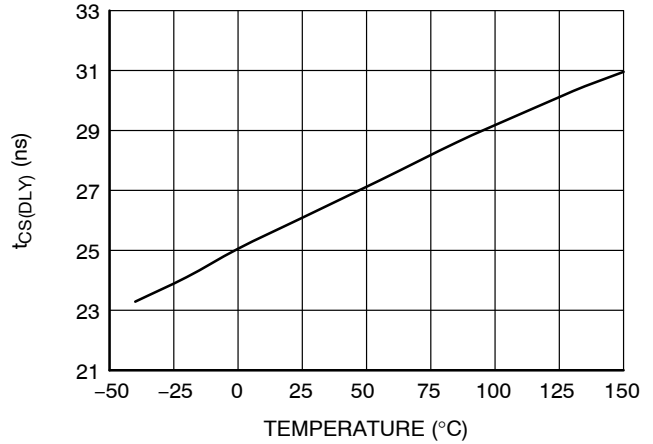

Figure 17. $t_{cs(DLY)}$ vs. Temperature

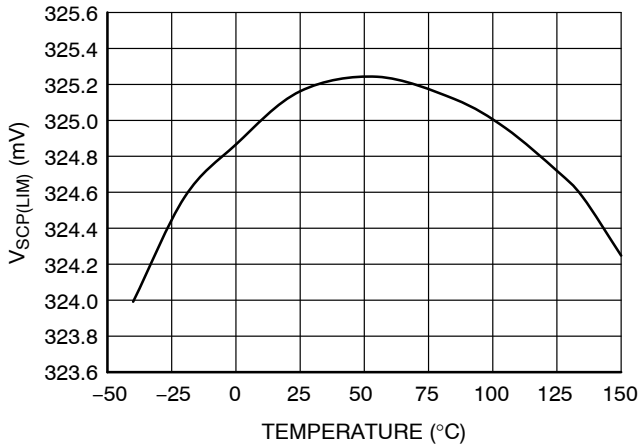

Figure 18. $V_{scf(LIM)}$ vs. Temperature

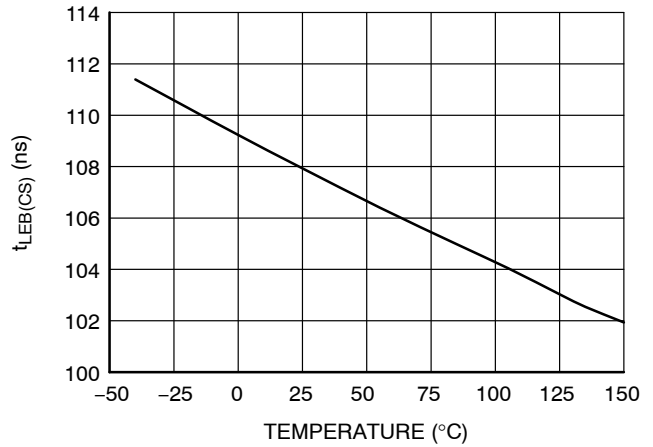

Figure 19. $t_{LEB(CS)}$ vs. Temperature

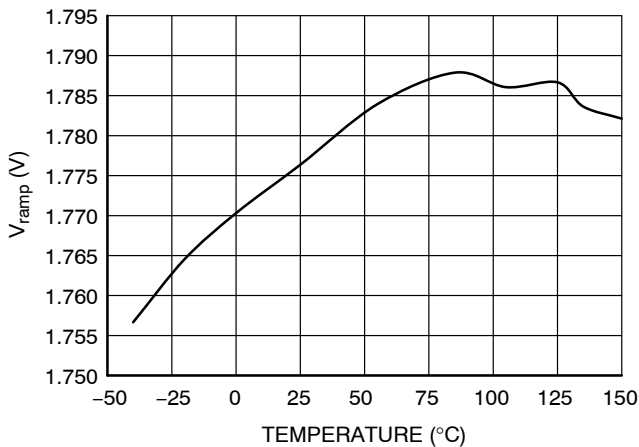

Figure 20. V_{ramp} vs. Temperature

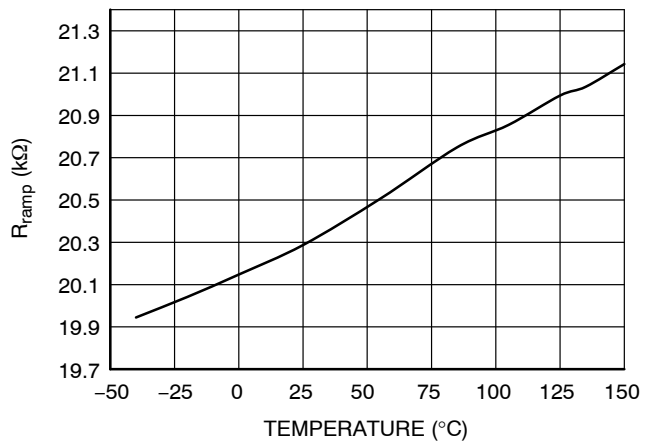

Figure 21. R_{ramp} vs. Temperature

TYPICAL CHARACTERISTICS (continued)

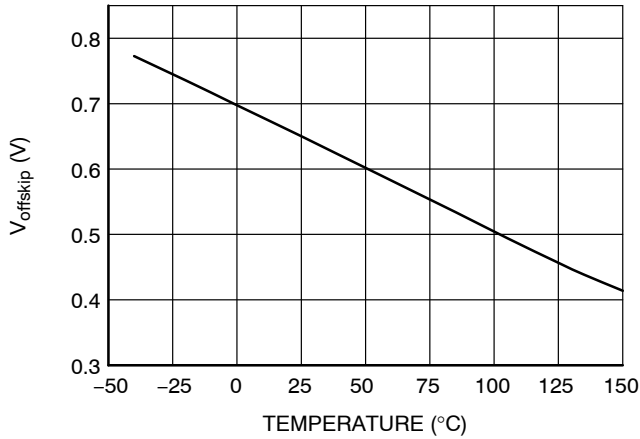

Figure 22. V_{offskip} vs. Temperature

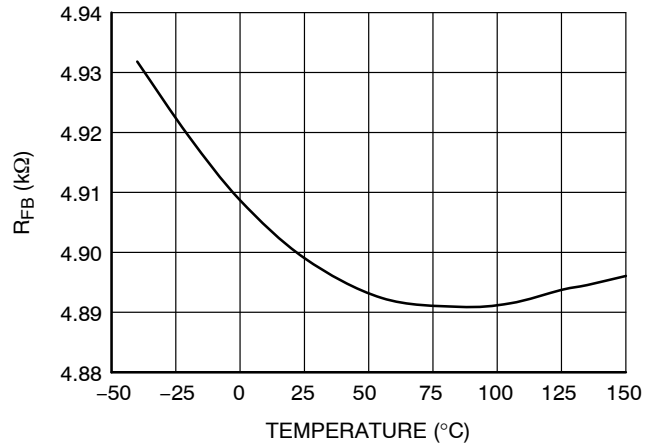

Figure 23. R_{FB} vs. Temperature

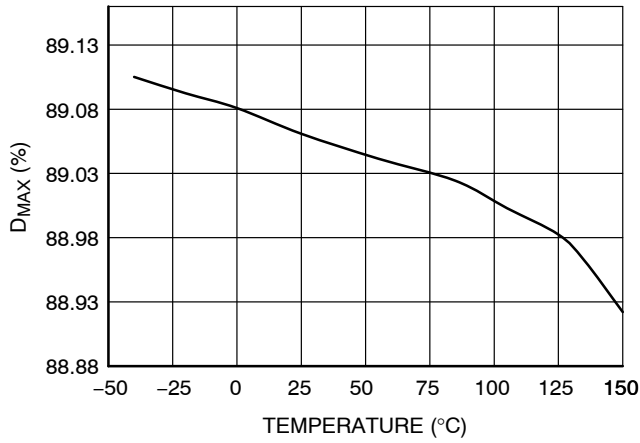

Figure 24. D_{MAX} vs. Temperature

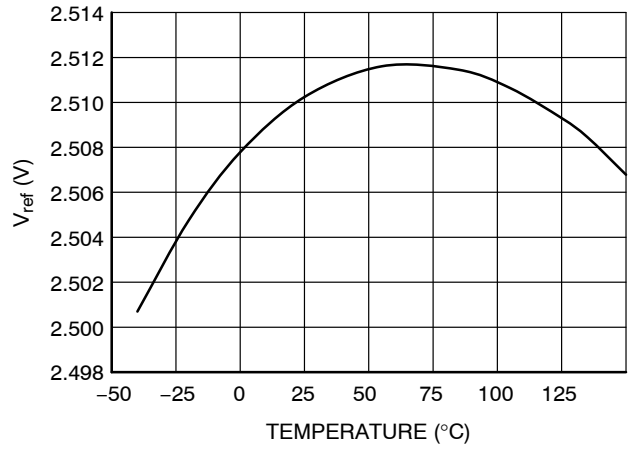

Figure 25. V_{ref} vs. Temperature

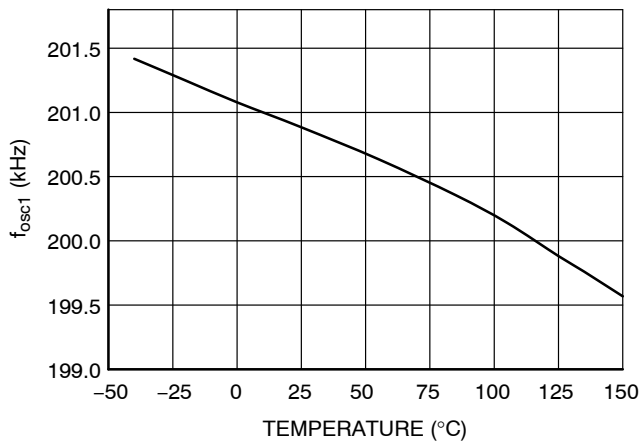

Figure 26. f_{osc1} vs. Temperature

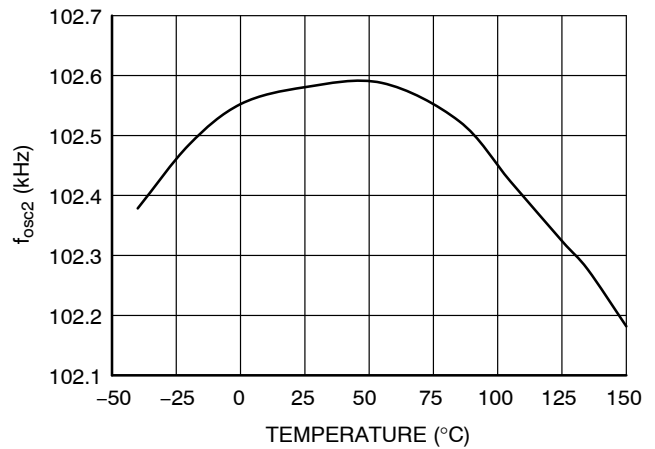

Figure 27. f_{osc2} vs. Temperature

TYPICAL CHARACTERISTICS (continued)

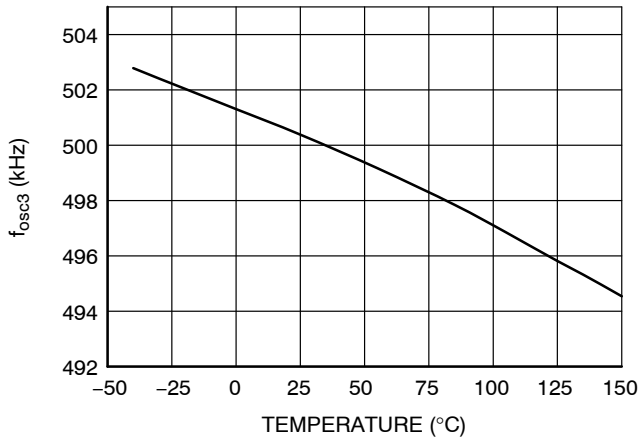

Figure 28. f_{osc3} vs. Temperature

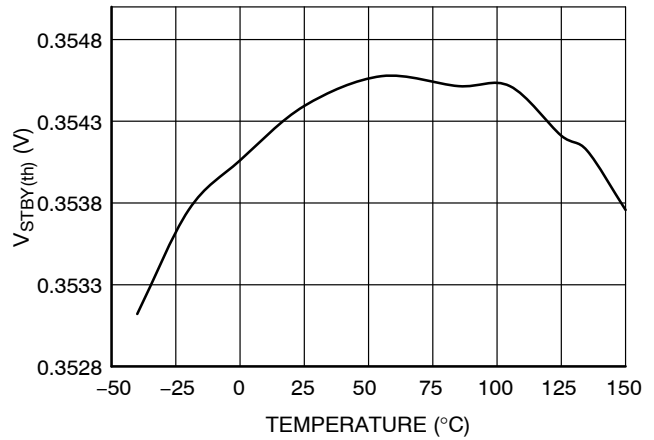

Figure 29. $V_{STBY(th)}$ vs. Temperature

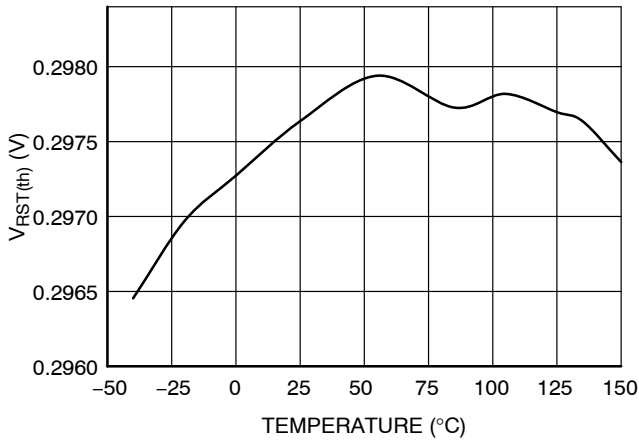

Figure 30. $V_{RST(th)}$ vs. Temperature

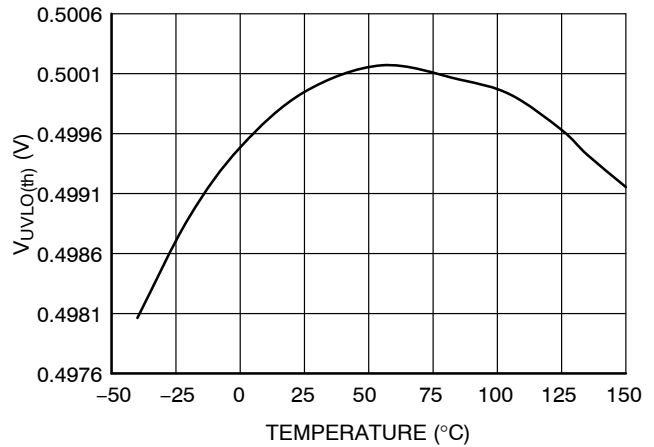

Figure 31. $V_{UVLO(th)}$ vs. Temperature

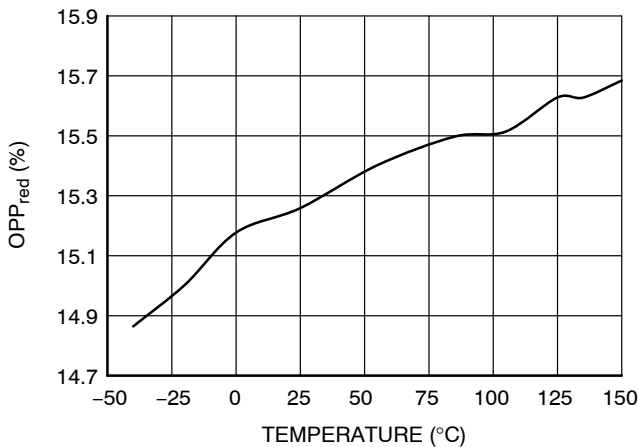

Figure 32. OPP_{red} vs. Temperature

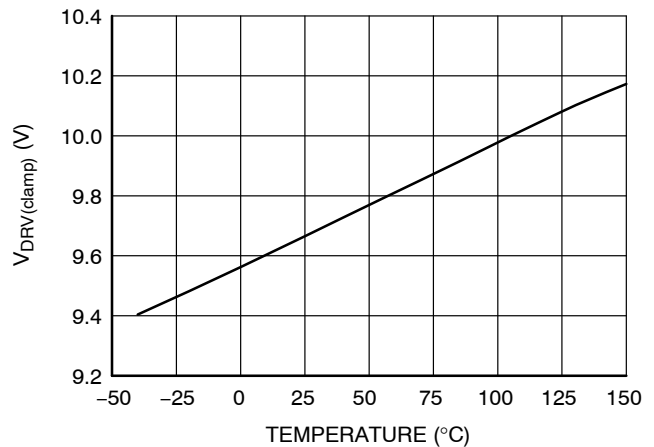

Figure 33. $V_{DRV(clamp)}$ vs. Temperature

APPLICATION INFORMATION

NCV12711 implements a standard current-mode architecture where the switch-off event is dictated by the peak current setpoint. This component represents the ideal candidate where low part-count and cost effectiveness are key design parameters, particularly in dc-dc converters modules and open-frame power supplies. NCV12711 brings all the necessary components normally needed in today modern power supply designs.

- *Current-mode operation with internal slope compensation:* implementing peak current mode control at a fixed operating frequency, the NCV12711 includes an externally-adjustable slope compensation scheme. By sizing a single resistance connected in series with the CS pin, the designer has the ability to tailor the compensation level exactly to his needs.
- *0% duty ratio operation:* the loop can program a 0-A peak current setpoint when it imposes 640 mV on the error amplifier COMP pin. It means, the width of the DRV pulse is a minimum t_{on} (LEB + propagation delay). If V_{out} keeps increasing in this situation, the regulation is lost and the IC goes to skip mode with no DRV pulse. It ensures that the IC will safely skip cycles at minimum t_{on} during light load, preventing output runaway while keeping output ripple at a minimum.
- *Internal regulator:* the part includes an internal regulator powering the device from 4 to 45 V without the need to resort to an auxiliary winding. When power dissipation is at stake, it is possible to lift the VCC pin up via an auxiliary winding and permanently disable the regulator.
- *Input voltage monitoring:* the UVLO pin observes the input voltage through a resistive divider. This pin serves two purposes: a) it ensures the converter operates within the range it has been designed for and b) it routes this information to a power-limiting path for over-power protection (OPP).
- *Internal OPP:* the part internally buffers the UVLO voltage and reduces the maximum peak current setpoint at high input line. Please note that the OPP current starts from 0% when the UVLO voltage is 1.0 V, a low-line condition. It helps pass maximum power at the lowest input voltage despite some compensation at high line. OPP is also disabled during the start-up sequence or in light-load operation.
- *Internal soft-start:* a soft-start precludes the main power switch from being stressed upon start up and it reduces output voltage overshoots. In this controller, the soft-start can be adjusted by a simple capacitor to ground. Beside peak current smooth increase brought by this mechanism, the switching frequency starts from a low 30-kHz value

and increases along the soft-start sequence. Soft-start is activated when a new startup sequence occurs or during an auto-recovery hiccup.

- *On-board op-amp:* an op-amp allows the implementation of non-isolated dc-dc converters but also isolated versions in which the rectified auxiliary voltage is used for regulation.
- *V_{cc} OVP:* an OVP protects the circuit against V_{cc} runaways. The fault must be present at least 7 μ s to be validated. This OVP is auto-recovery.
- *Short-circuit protection:* short-circuit and especially over-load protections are difficult to implement when a strong leakage inductance between auxiliary and power windings affects the transformer (the auxiliary winding level does not properly collapse in presence of an output short). In this controller, every time the internal 0.25-V maximum peak current limit is activated (or less when OPP is active), an error flag is asserted and a time period starts, thanks to the programmable timer. When the timer has elapsed, the controller enters an auto-recovery mode with a 1-s recurrence.
- *Winding or diode short circuit protection:* in case the secondary-side winding (or even the rectifying diode) is shorted, the primary-side current can grow very quickly with possibly-lethal conditions in the converter. An extra comparator with a smaller LEB monitors if the peak current exceeds 25% of the maximum value ($250 \text{ mV}/R_{sense}$) four consecutive times. At the end of this sequence, the converter enters auto-recovery mode.

Supplying the Controller

The component integrates a start-up current source supplied from the VIN pin and capable of sourcing up to 20 mA typically to the VCC pin. When V_{cc} reaches the regulation level of 7.5 V, the startup is a linear regulator which can continue to supply and regulate V_{cc} at 7.5 V. The recommended VCC capacitance to ensure stability of the regulator is 1 – 10 μ F. This source is a dual-current type meaning that if for any reason the V_{cc} is shorted to ground, the current is safely limited to 2.5 mA, preventing any lethal runaway at a high input voltage. When the short circuit is released and V_{cc} exceeds a certain voltage level (200 mV typical), the source is back to its 20-mA setpoint. The 20-mA are typically specified for a 12-V level on the VIN pin but the part will deliver current as soon as a bias appears on the part. Figure 34 shows a simulated start-up sequence with VIN plateauing at 4 V for some time before taking off towards 15 V. The driving pulses follow the voltage and are clamped at the 7.5-V voltage later on.

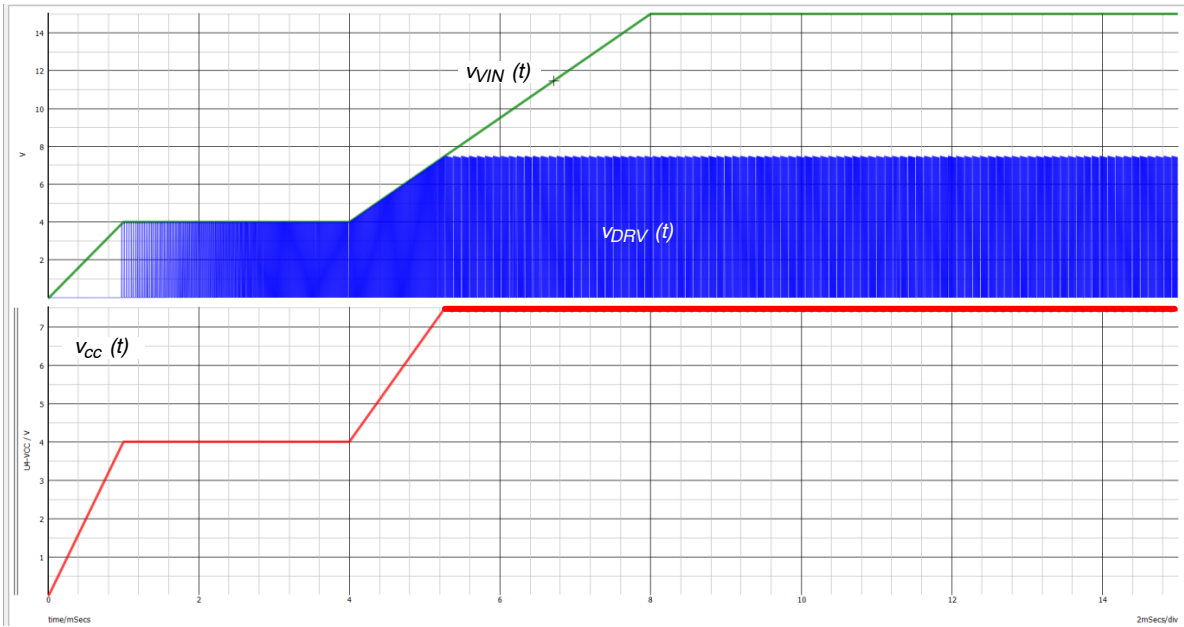

Figure 34. The LDO is Activated During the Start-up Sequence and Powers the Controller

As the LDO supplies the controller, it sees the average current absorbed by the controller. This current is approximately made of $I_{CC(EN)}$ plus the MOSFET driving current leading to a total current equal to:

$$I_{LDO} \approx I_{CC(EN)} + I_{DRV} \approx I_{CC(EN)} + f_{sw}Q_G \quad (\text{eq. 1})$$

Assume you have selected a MOSFET featuring a 35-nC total gate charge Q_G and operate it at 250 kHz. The average current flowing in the LDO will be:

$$I_{LDO} \approx 4 \text{ m} + 250 \text{ k} \cdot 35 \text{ n} \approx 12.8 \text{ mA} \quad (\text{eq. 2})$$

This current multiplied by the maximum voltage at the VIN pin will define the controller average power dissipation:

$$P_{LDO} = I_{LDO}V_{VIN} \quad (\text{eq. 3})$$

If we assume a $R_{\theta J-A}$ of 130°C/W when the part is soldered on a wide copper area, then the maximum VIN voltage at a 50°C ambient temperature will be:

$$V_{in,max} < \frac{T_J - T_A}{R_{\theta J-A} I_{LDO}} \quad (\text{eq. 4})$$

Assume a junction temperature limit of 110°C and a maximum ambient of 60°C, then the maximum bias voltage for this circuit while the LDO is permanently activated would be:

$$V_{in,max} < \frac{110 - 60}{130 \times 12.8 \text{ m}} \approx 30 \text{ V} \quad (\text{eq. 5})$$

Beyond this value, risks exist to damage the die by excessive power dissipation. To benefit from the full voltage range up to 45 V, it is recommended to a) reduce the dissipated power by lowering f_{sw} and adopting a low- Q_G power MOSFET and/or b) add an auxiliary winding to the transformer and use the LDO as a simple one-shot start-up source (Figure 35).

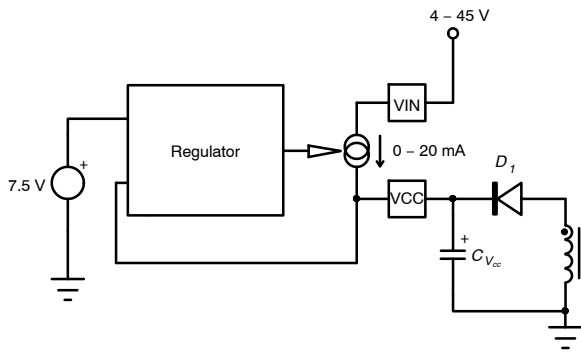

Figure 35. The LDO Can Be Associated with an Auxiliary Winding and Be Turned Off in Normal Operation

Protecting the VCC Pin

The VCC pin is protected by an over-voltage detection circuitry which immediately reacts as soon as the bias on this pin exceeds 27 V typically (25 V minimum). When the fault happens and lasts more than 7 μs, all pulses are immediately stopped and the circuit remains silent for 1 s. It resumes operation via a soft-start sequence and goes back to normal mode if the fault has gone. This function is there to protect the controller in case you would accidentally supply it with a large voltage on the auxiliary winding for instance if the control loop fails. In some low-voltage applications, you can directly supply the controller from the input rail by shorting the VIN and VCC pins together (Figure 36).

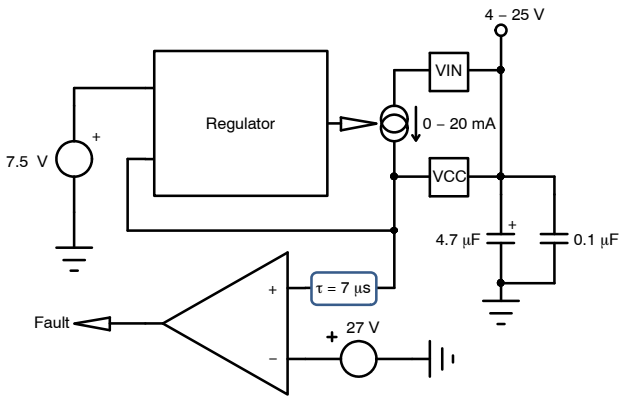

Figure 36. For Low-voltage Applications, it is Possible to Connect the VIN and VCC Pins Together. The OVP on the VCC Pin Remains Active and will Stop Pulses if the Input Rail Exceeds 27 V.

The short circuit between the pins bypasses the LDO and the whole circuit is fed by the input rail. Make sure the input rail voltage always remain below the OVP voltage otherwise the controller will stop working. In the example, the 25-V limit corresponds to the minimum of the OVP specification.

Monitoring the Input Voltage

It is important to check that the converter operates within an authorized input voltage range. For that purpose, the UVLO pin permanently monitors a scaled-down image of the input rail and turns the IC on or off accordingly. A simplified view of the internal circuitry is shown in Figure 37.

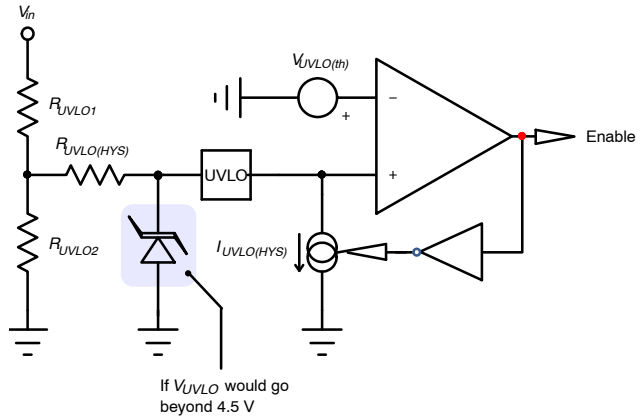

Figure 37. A Comparator Turns The IC On or Off Depending the VIN Pin Bias Level

The turn-on and -off voltages can be obtained using the following formulas:

$$V_{on} = [V_{UV(th)} + (R_{UVLO1} \parallel R_{UVLO2} + R_{HYS}) I_{UV(HYS)}] \frac{R_{UVLO1} + R_{UVLO2}}{R_{UVLO2}} \quad (\text{eq. 6})$$

$$V_{off} = (V_{UVLO(th)} - V_{UVLO(HYS)}) \frac{R_{UVLO1} + R_{UVLO2}}{R_{UVLO2}} \quad (\text{eq. 7})$$

From these expressions, resistors setting the turn-on and -off levels are determined with the below equations in which R_{UVLO2} is arbitrarily fixed:

$$R_{UVLO(HYS)} = \frac{(V_{UVLO(th)} - V_{UVLO(HYS)}) V_{on} + I_{UVLO(HYS)} R_{UVLO2} (V_{UVLO(th)} - V_{UVLO(HYS)}) - V_{off} (V_{UVLO(th)} + I_{UVLO(HYS)} R_{UVLO2})}{I_{UVLO(HYS)} V_{off}} \quad (\text{eq. 8})$$

$$R_{UVLO1} = \frac{R_{UVLO2} (V_{off} - V_{UVLO(th)} + V_{UVLO(HYS)})}{V_{UVLO(th)} - V_{UVLO(HYS)}} \quad (\text{eq. 9})$$

As an example, if $R_{UVLO2} = 10 \text{ k}\Omega$ and you select an 8-V turn-on voltage with a 6-V turn-off level, then $R_{HYS} = 20 \text{ k}\Omega$ and $R_{UVLO1} = 114 \text{ k}\Omega$. The Excel sheet posted on the NCV12711 landing page automates the calculation of these resistors. As a final note, once the resistive divider is determined, it is important to verify that the maximum voltage on the UVLO pin does not approach or exceed its 5.5-V maximum rating at the maximum input voltage. Should it be the case, you will have to install a 4.7-V Zener

diode at the UVLO pin to keep the pin voltage within its safe operating area.

Limiting the Power Excursion at High Input Voltage

It is a well-known phenomenon that the maximum power delivered by a flyback converter varies with the input voltage. Assuming a wide input range design, your converter can potentially exhibit more current for the output diode at high line than at low line with detrimental effects for

reliability. This is because the converter is designed to deliver its nominal power at the lowest input voltage. Transition to DCM and propagation delays are the reason why the power capability changes with the input voltage.

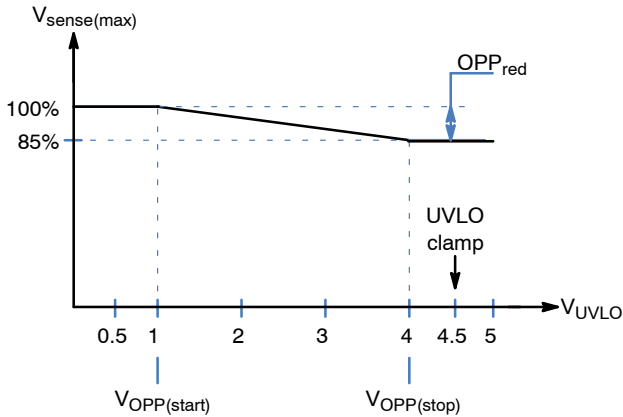

Figure 38. The Maximum Peak Current Reduces with the Input Voltage and Reaches 85% of its Nominal Value at the Highest Input Voltage

NCV12711 embarks an over-power protection (OPP) scheme which reduces the maximum peak current setpoint when the UVLO voltage varies from 1 V (low line) to 4 V where the OPP is no longer active. The peak setpoint will reduce by 15% when the UVLO hits 4 V (Figure 38). An option exists to turn OPP permanently off, please contact sales for that purpose.

Soft-Start Sequence

To limit the stress on primary- and secondary-sides, the NCV12711 incorporates a soft-start circuitry which smoothly increases the peak current setpoint cycle-by-cycle but also sweeps the switching frequency. The converter starts with an almost 0-A setpoint at a 30-kHz frequency and increases this value up to the nominal selection. A capacitor is charged by a 15-μA current source up to 2 V where the sequence has ended. The capacitor is thus selected based on the wanted soft-start duration:

$$C_{SS} = \frac{I_{SS}t_{SS}}{V_{SS(end)}} = \frac{15 \mu \times 10 \text{ m}}{2} = 75 \text{ nF} \quad (\text{eq. 10})$$

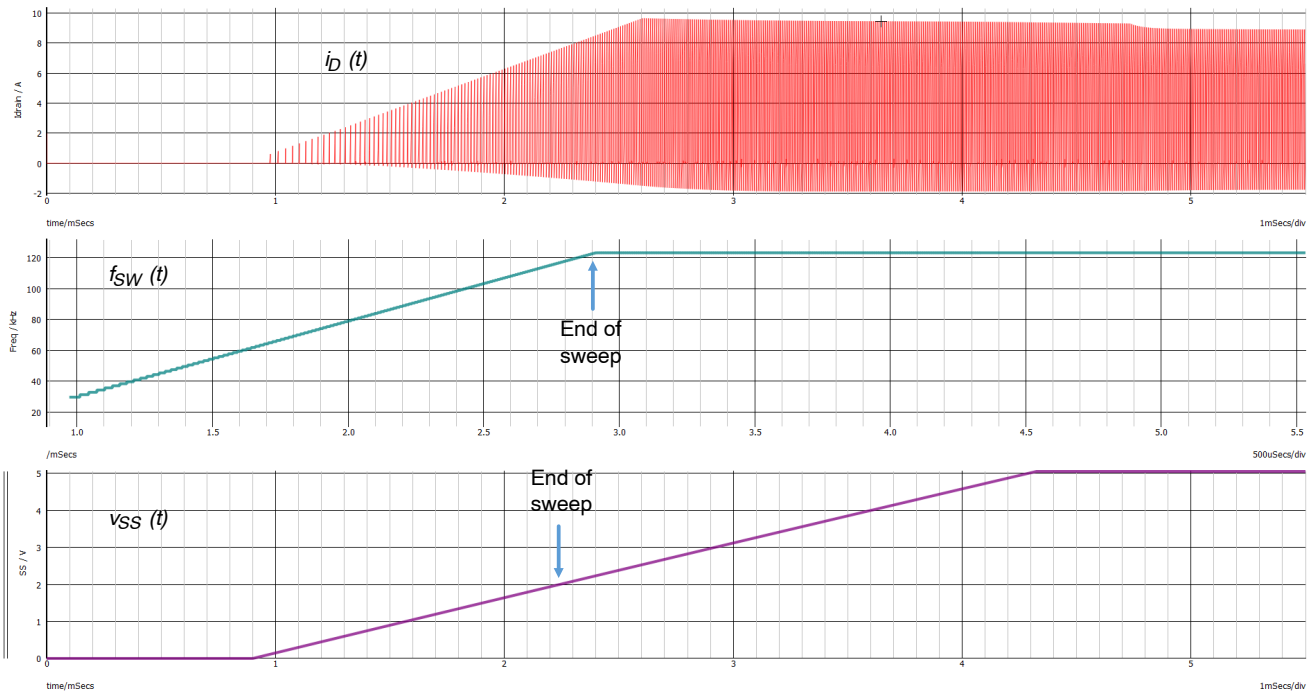

Figure 39. The Peak Current is Smoothly Ramped Up as Well as the Switching Frequency Which Starts from a Low 30 kHz

Figure 39 shows a typical start-up sequence highlighting current and frequency variations during this sequence. Please note the different time scale for the frequency plot.

The frequency sweep ensures the lowest possible stress at power up and is especially interesting when secondary-side synchronous rectification is used: in absence of output voltage, the MOSFET body diode plays the rectifier role until the control circuit takes the lead when sufficiently powered. In absence of a smooth frequency ramp-up,

violent voltage spikes can appear across the synchronous MOSFET and may destroy it. A slow frequency increase ensures a limited stress until the synchronous circuit is fully operational.

Feedback and Current Sense

The controller hosts an operational amplifier (op-amp) useful for either non-isolated dc-dc or primary-side-operated isolated flyback converters. The

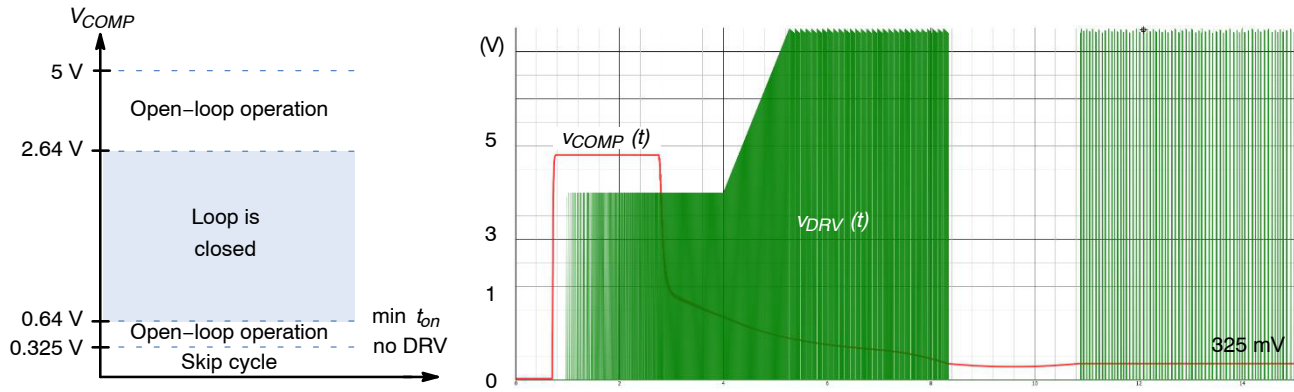

Figure 41. The COMP Pin Swings between 2.64 V and 0.64 V for a 0-A Peak Setpoint. Skip Cycle Operation Happens when the Loop Fails to Regulate at the Lowest Possible Peak Current Setpoint.

Slope Compensation

Current-mode power supplies are prone to sub-harmonic oscillations. This is because the inner current-loop gain crossover frequency is too high and there is no phase margin at this point. The condition happens when the converter operates in continuous conduction mode (CCM) with a duty ratio approaching 50%. A simple cure for these sub-harmonic oscillations is to inject a compensation ramp S_e which will reduce the current-loop gain. It can be done in several ways but the simplest one is to sum the ramp with the current sense information. NCV12711 integrates an artificial ramp derived from the oscillator. Once buffered, it biases the CS pin via a 20-k Ω resistor (Figure 42) only during the on-time. Inserting a resistance in series with the sensed voltage offers a simple means to adjust the compensation effort. If you do not want compensation, simply reduce this resistance or suppress it provided your PCB layout is clean.

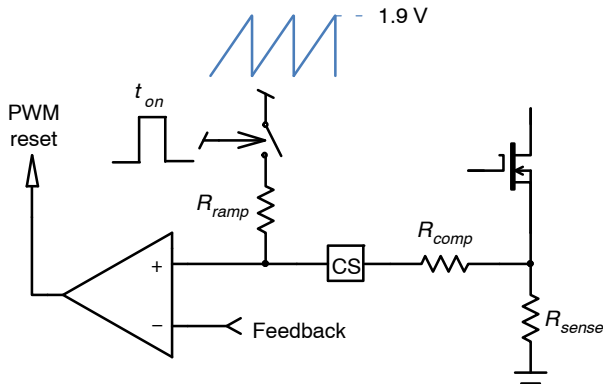

Figure 42. You Can Easily Adjust the Slope Compensation Level you Need by Inserting a Resistance in Series with the CS Pin

To determine the value of R_{comp} , you first need to determine the primary-side inductor current downslope S_f . Once scaled to volts per second via the sense resistance, we have:

$$S_f = \frac{V_{out} + V_f}{NL_p} R_{sense} \tag{eq. 14}$$

In which V_f is the secondary-side rectifier drop, N is the 1: N transformer turns ratio, L_p the primary-side inductance and R_{sense} the current sensing resistance. The compensation slope is given in the data-sheet and depends on the selected switching period:

$$S_e = \frac{V_{ramp}}{D_{max} T_{sw}} \tag{eq. 15}$$

Now, compute the division ratio value between S_e , the existing ramp level and what you want to inject. If we select a compensation level equal to 50% of the inductor downslope current, then the division ratio equals:

$$\text{divratio} = \frac{0.5 \times S_f}{S_e} = \frac{0.5 \cdot D_{max} R_{sense} T_{sw} (V_{out} + V_f)}{L_p N V_{ramp}} \tag{eq. 16}$$

Then, the resistance to add in series with the CS pin is simply:

$$R_{comp} = \text{divratio} \times R_{ramp} \tag{eq. 17}$$

Assume the following data: $L_p = 5 \mu\text{H}$, $R_{sense} = 0.03 \Omega$, $D_{max} = 90\%$, $F_{sw} = 100 \text{ kHz}$, $R_{ramp} = 20 \text{ k}\Omega$, $N = 1.25$ and $V_{ramp} = 1.9 \text{ V}$. Applying the above formulas to a 5-V converter leads to a compensation resistance value of 1.4 k Ω :

$$\begin{aligned} V_{out} &:= 5 \text{ V} & N_{turns} &:= 1.25 & R_{ramp} &:= 20 \text{ k}\Omega & R_{sense} &:= 0.03 \Omega \\ L_p &:= 5 \mu\text{H} & D_{max} &:= 90\% & F_{sw} &:= 100 \text{ kHz} & k_{comp} &:= 50\% \\ V_{ramp} &:= 1.9 \text{ V} & T_{sw} &:= \frac{1}{F_{sw}} & V_f &:= 0.5 \text{ V} \\ S_e &:= \frac{V_{ramp}}{T_{sw}} = 0.19 \frac{\text{V}}{\mu\text{s}} & S_f &:= \frac{V_{out} + V_f}{N_{turns} \cdot L_p} \cdot R_{sense} = 0.026 \frac{\text{V}}{\mu\text{s}} \\ \text{divratio} &:= \frac{k_{comp} \cdot S_f}{S_e} = 0.069 \\ R_{comp} &:= R_{ramp} \cdot \text{divratio} = 1.389 \times 10^3 \Omega \\ \frac{k_{comp} \cdot R_{sense} \cdot T_{sw} \cdot (V_{out} + V_f)}{L_p \cdot N_{turns} \cdot V_{ramp}} \cdot R_{ramp} &= 1.389 \text{ k}\Omega \end{aligned}$$

Figure 43. The Compensation Resistance is Easily Determined with a few Calculation Steps

Short Circuit Protection

If the loop asks for the maximum power, the peak-current setpoint is clamped to 250 mV (no OPP). When this happens, the controller arms an error flag signaling a fault condition. This naturally occurs during the start-up sequence until the converter regulates and resets the flag. A fault timer of 30 ms starts every time the error flag is asserted. When the timer reaches completion, all pulses are stopped and the part remains silent for 1 s. If the auxiliary winding disappears during the 1-s off-mode, the LDO takes over and supplies the part. At the end of the 1-s period, a fresh start-up sequence takes place with soft-start and frequency sweep. If the fault has disappeared, the converter

recovers and resumes operation. If the fault is still present, a new 1-s off-mode takes place and the converter keeps ticking as long as the fault remains. Figure 44 describes a start-up sequence leading to a regulated output and suddenly followed by an output short circuit. The error flag is asserted immediately and the timer starts counting. During this time, the peak current is pushed to the maximum value. When the timer has elapsed, all pulses stop and the 1-s off-time period starts. Then the power supply attempts to resume operations (not shown). The overload timer is set to 30 ms but longer periods of time are available upon request to the factory. Please contact your sales person for more information.

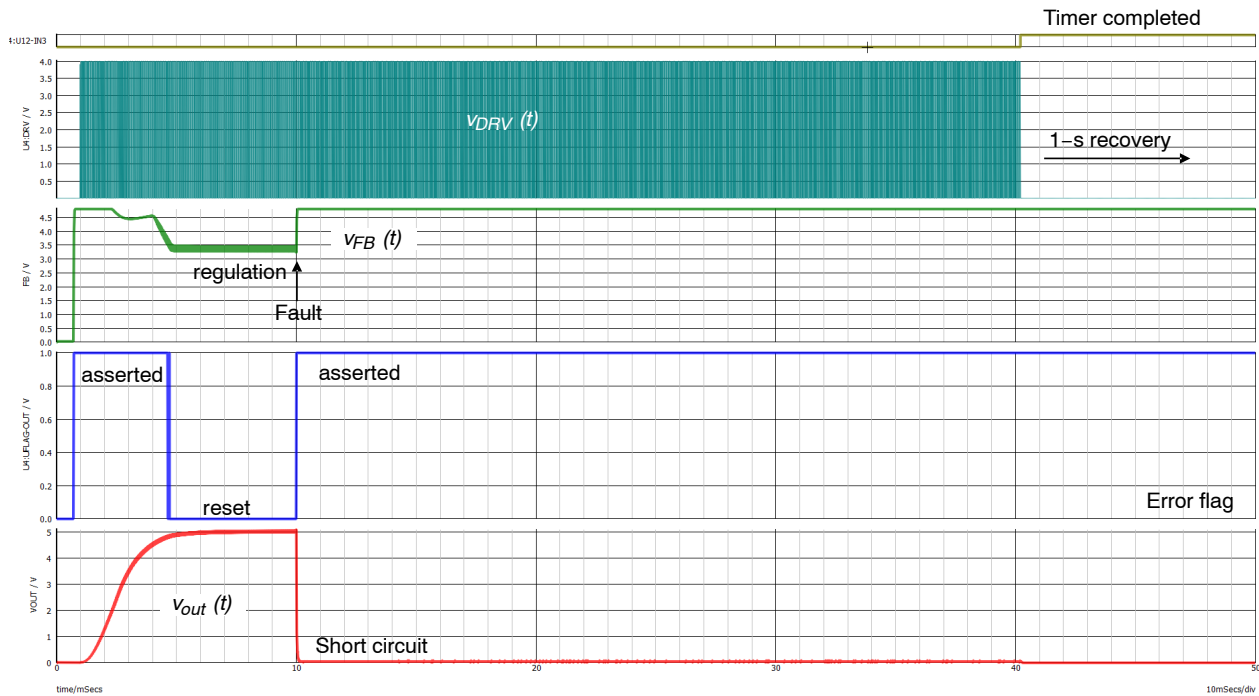

Figure 44. The Circuit Auto-recovers from a Short Circuit or an Overload Situation

In case the peak current measured at the CS pin largely exceeds the 250-mV voltage setpoint, a second over-current comparator trips. This second comparator benefits from a smaller LEB duration (60 ns versus 110 ns) and reacts in case the sensed voltage exceeds the 250-mV

limit by 25%: $V_{SCP(LIM)}$. When such an event occurs, e.g. when the secondary diode fails shorted, the controller counts 4 consecutive events and stops all pulses immediately. The part then waits 1 s before attempting to restart. The internal circuitry appears in Figure 45.

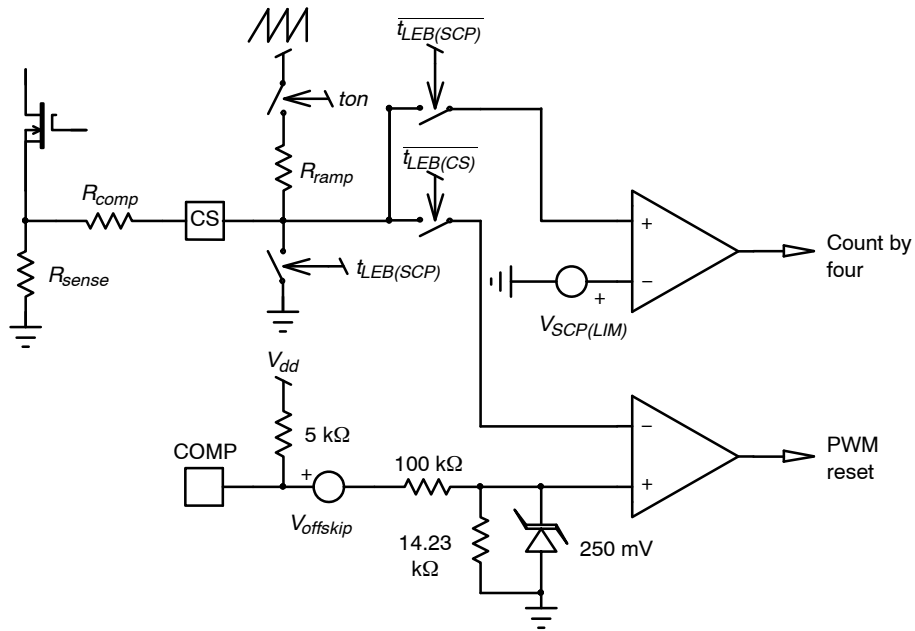

Figure 45. If the Current Sense Pin Exceeds the Maximum Cycle-by-cycle Limit by 25%, a Counter Records the Event and Stops All Pulses after 4 Consecutive Events

Operational Amplifier

The on-board op-amp exhibits a gain-bandwidth product (GBW) of 1.4 MHz with a low-frequency pole located at 53 Hz. It features an open-drain configuration loaded by the internal 5-kΩ pull-up resistor. With this circuit, it is possible to implement a type 2 compensator hosting a pole at the origin, one zero and one pole. Such configuration is shown in Figure 46 with its typical ac response in the right side. The type 2 lends itself well to stabilizing current-mode dc-dc converters. The characteristics of such compensator are described by the following transfer functions:

$$G(s) = -G_0 \frac{1 + \frac{\omega_z}{s}}{1 + \frac{s}{\omega_p}} \quad (\text{eq. 18})$$

In which:

$$G_0 = \frac{R_2}{R_1} \frac{C_1}{C_1 + c_2} \approx \frac{R_2}{R_1} \quad (\text{eq. 19})$$

$$\omega_z = \frac{1}{R_2 C_1} \quad (\text{eq. 20})$$

$$\omega_p = \frac{1}{R_2 C_1 + C_2} \approx \frac{1}{R_2 C_1} \quad (\text{eq. 21})$$

Approximated formulas are valid when we have $C_2 \ll C_1$.

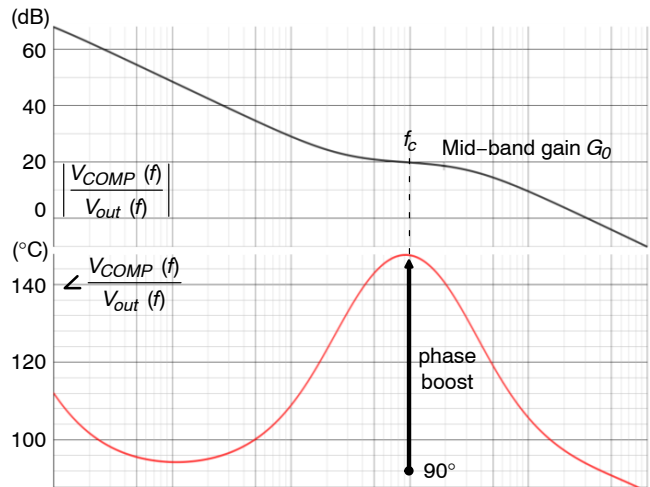
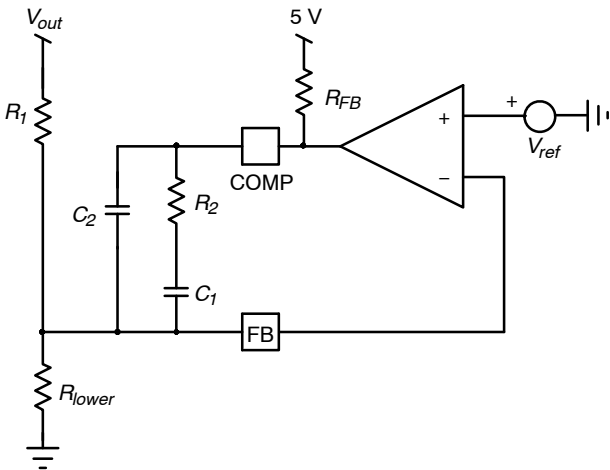

Figure 46. The On-board op-amp Lets you Realize a Type 2 Compensator which is Adequate for Stabilizing Current-mode dc-dc Converters

The op-amp own characteristic can be neglected if the selected crossover frequency is moderate, around the kHz for instance. However, if you plan to extend crossover at 10 kHz or so, then it is important to verify the compensator response once the op-amp characteristic is accounted for especially if a high gain is required at crossover. A separate application note covers a compensation exercise in details.

NCV12711 lends itself well to opto-isolated applications also. Just ground the feedback pin and connect the opto-coupler collector to the COMP pin with a capacitor for the pole generation together with R_{FB} .

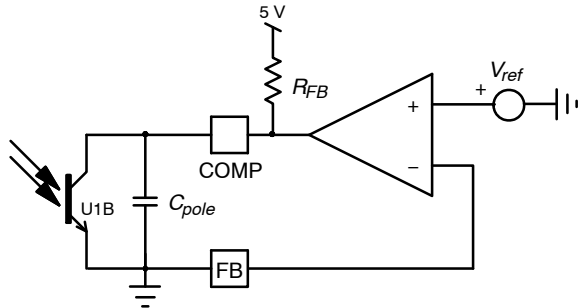

Figure 47. If you Tie the FB Pin to Ground, then an Opto-isolator Can Pull the COMP Pin Down for Regulation Purposes

Oscillator

The oscillator lets you select a switching frequency from 100 kHz up to 1 MHz. By pulling the R_t pin to ground via a resistance, it is possible to select the switching frequency. The curve from Figure 48 links the switching frequency with the resistance value. An approximate formula lets you also determine the resistance as follows:

$$R_t \approx \frac{8.9 \cdot 10^9}{F_{sw} - 30 \text{ k}} \tag{eq. 22}$$

Assuming a wanted 100-kHz operation, you would select a resistance of

$$R_t = \frac{8.9 \cdot 10^9}{100 \text{ k} - 30 \text{ k}} \approx 127 \text{ k}\Omega \tag{eq. 23}$$

A quick experiment on the prototype will let you know if you need to keep or slightly adjust this value. The following array suggest values for some typical switching frequencies:

Table 1.

Frequency (kHz)	R_t (k Ω)
100	127
150	74.2
200	52.4
250	40.5
300	33
350	27.8
400	24

For stability reasons, it is usually not recommended to decouple the R_t pin with a capacitor.

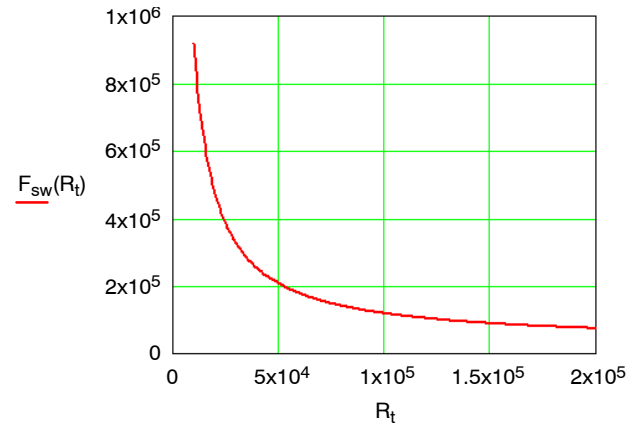

Figure 48. You Can Extract the R_t Resistance Value from the Graph or Compute it with the Approximate Expression

NCV12711

Application Circuits

The NCV12711 can be used in a variety of applications. Figure 49 represents a 100-kHz flyback converter

regulating the auxiliary winding at 12 V. This is a wide-range application since the board operates from a 4–V input voltage up to 45 V. the precision

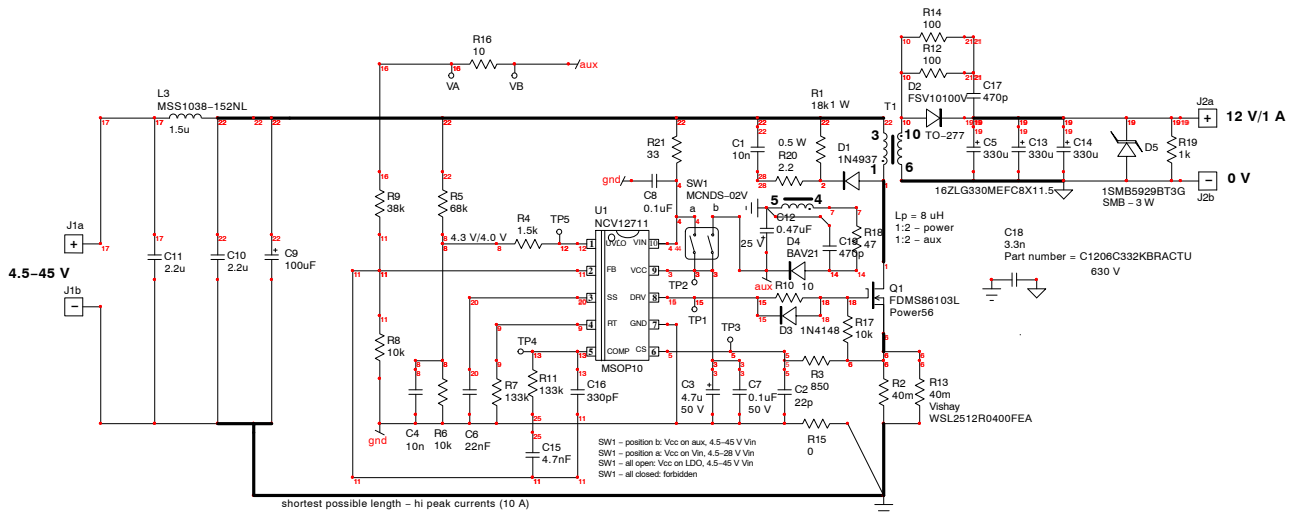

Figure 49. 4.5 – 45 V Input Voltage Isolated Flyback Converter Delivering 12 V/1 A

Figure 50 represents a 5-V/2-A application circuit operated from a 4.5-to-10-V input source, a typical industrial board-mounted module. A synchronous rectifier

ensures a good overall efficiency. There is no auxiliary winding on this board.

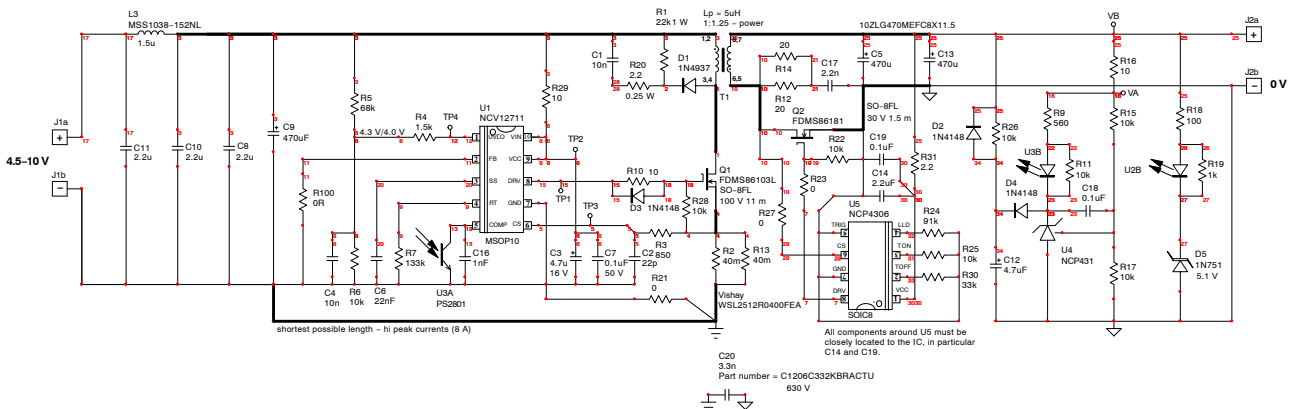
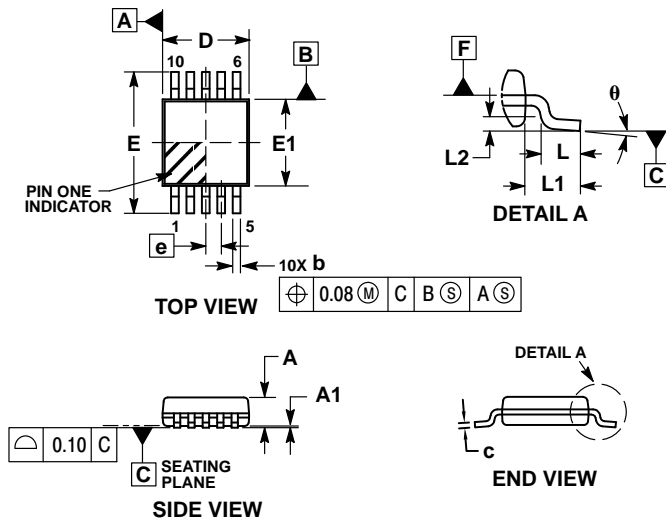

Figure 50. 4.5 – 10 V 5-V/2-A Opto-isolated dc-dc Flyback Module

SCALE 1:1

MSOP10, 3x3
CASE 846AE
ISSUE A

DATE 20 JUN 2017



TOP VIEW $\oplus 0.08$ (M) C B (S) A (S)

SIDE VIEW

END VIEW

RECOMMENDED
SOLDERING FOOTPRINT*

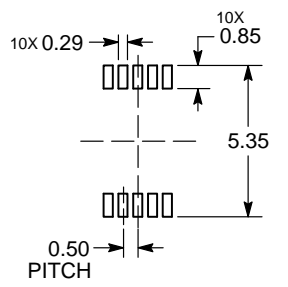

DIMENSIONS: MILLIMETERS

*For additional information on our Pb-Free strategy and soldering details, please download the onsemi Soldering and Mounting Techniques Reference Manual, SOLDERRM/D.

NOTES:

1. DIMENSIONS AND TOLERANCING PER ASME Y14.5M, 1994.
2. CONTROLLING DIMENSIONS: MILLIMETERS.
3. DIMENSION b DOES NOT INCLUDE DAMBAR PROTRUSION. ALLOWABLE DAMBAR PROTRUSION SHALL BE 0.10 MM IN EXCESS OF MAXIMUM MATERIAL CONDITION.
4. DIMENSION D DOES NOT INCLUDE MOLD FLASH, PROTRUSIONS, OR GATE BURRS. MOLD FLASH, PROTRUSIONS, OR GATE BURRS SHALL NOT EXCEED 0.15 MM PER SIDE. DIMENSION E DOES NOT INCLUDE INTERLEAD FLASH OR PROTRUSION. INTERLEAD FLASH OR PROTRUSION SHALL NOT EXCEED 0.25 MM PER SIDE. DIMENSIONS D AND E ARE DETERMINED AT DATUM F.
5. DATUMS A AND B TO BE DETERMINED AT DATUM F.
6. A1 IS DEFINED AS THE VERTICAL DISTANCE FROM THE SEATING PLANE TO THE LOWEST POINT ON THE PACKAGE BODY.

DIM	MILLIMETERS		
	MIN	NOM	MAX
A	---	---	1.10
A1	0.00	0.05	0.15
A2	0.75	0.85	0.95
b	0.17	---	0.27
c	0.13	---	0.23
D	2.90	3.00	3.10
E	4.75	4.90	5.05
E1	2.90	3.00	3.10
e	0.50 BSC		
L	0.40	0.70	0.80
L1	0.95 REF		
L2	0.25 BSC		
θ	0°	---	8°

GENERIC
MARKING DIAGRAM*

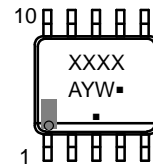

- XXXX = Specific Device Code
- A = Assembly Location
- Y = Year
- W = Work Week
- = Pb-Free Package

(Note: Microdot may be in either location)

*This information is generic. Please refer to device data sheet for actual part marking. Pb-Free indicator, "G" or microdot "▪", may or may not be present and may be in either location. Some products may not follow the Generic Marking.

DOCUMENT NUMBER:	98AON34098E	Electronic versions are uncontrolled except when accessed directly from the Document Repository. Printed versions are uncontrolled except when stamped "CONTROLLED COPY" in red.
DESCRIPTION:	MSOP10, 3X3	PAGE 1 OF 1

onsemi and ONSEMI are trademarks of Semiconductor Components Industries, LLC dba onsemi or its subsidiaries in the United States and/or other countries. onsemi reserves the right to make changes without further notice to any products herein. onsemi makes no warranty, representation or guarantee regarding the suitability of its products for any particular purpose, nor does onsemi assume any liability arising out of the application or use of any product or circuit, and specifically disclaims any and all liability, including without limitation special, consequential or incidental damages. onsemi does not convey any license under its patent rights nor the rights of others.

onsemi, **Onsemi**, and other names, marks, and brands are registered and/or common law trademarks of Semiconductor Components Industries, LLC dba "**onsemi**" or its affiliates and/or subsidiaries in the United States and/or other countries. **onsemi** owns the rights to a number of patents, trademarks, copyrights, trade secrets, and other intellectual property. A listing of **onsemi**'s product/patent coverage may be accessed at www.onsemi.com/site/pdf/Patent-Marking.pdf. **onsemi** reserves the right to make changes at any time to any products or information herein, without notice. The information herein is provided "as-is" and **onsemi** makes no warranty, representation or guarantee regarding the accuracy of the information, product features, availability, functionality, or suitability of its products for any particular purpose, nor does **onsemi** assume any liability arising out of the application or use of any product or circuit, and specifically disclaims any and all liability, including without limitation special, consequential or incidental damages. Buyer is responsible for its products and applications using **onsemi** products, including compliance with all laws, regulations and safety requirements or standards, regardless of any support or applications information provided by **onsemi**. "Typical" parameters which may be provided in **onsemi** data sheets and/or specifications can and do vary in different applications and actual performance may vary over time. All operating parameters, including "Typicals" must be validated for each customer application by customer's technical experts. **onsemi** does not convey any license under any of its intellectual property rights nor the rights of others. **onsemi** products are not designed, intended, or authorized for use as a critical component in life support systems or any FDA Class 3 medical devices or medical devices with a same or similar classification in a foreign jurisdiction or any devices intended for implantation in the human body. Should Buyer purchase or use **onsemi** products for any such unintended or unauthorized application, Buyer shall indemnify and hold **onsemi** and its officers, employees, subsidiaries, affiliates, and distributors harmless against all claims, costs, damages, and expenses, and reasonable attorney fees arising out of, directly or indirectly, any claim of personal injury or death associated with such unintended or unauthorized use, even if such claim alleges that **onsemi** was negligent regarding the design or manufacture of the part. **onsemi** is an Equal Opportunity/Affirmative Action Employer. This literature is subject to all applicable copyright laws and is not for resale in any manner.

ADDITIONAL INFORMATION

TECHNICAL PUBLICATIONS:

Technical Library: www.onsemi.com/design/resources/technical-documentation
onsemi Website: www.onsemi.com

ONLINE SUPPORT: www.onsemi.com/support

For additional information, please contact your local Sales Representative at www.onsemi.com/support/sales