

NCL30125 Daughter Board User's Manual



ON Semiconductor®

www.onsemi.com

The NCL30125 daughter board has been designed to replace a forward controller in an existing two-switch forward converter. This user's manual describes the procedure to make this test.

The NCL30125 is a fixed-frequency current-mode controller featuring the Dynamic Self-Supply (DSS). The controller hosts an adjustable switching frequency with jittering function operated in peak current mode control. When the power on the secondary side drops drastically, the part enters skip cycle while limiting the peak current that insures the output voltage regulation and excellent efficiency in light load condition. It features a timer-based fault detection that ensures the detection of overload and a brown-out protection against low input voltages.

Features

- Integrated High-side Driver
- Adjustable Switching Frequency up to 1 MHz with Frequency Jittering

EVAl BOARD USER'S MANUAL

- Peak Current-mode Control
- Skip Mode to Maximize Performance in Light Load Conditions
- High-voltage Current Source with DSS
- Brown-out (BO) Detection
- Adjustable Soft-start Duration
- 15-ms Timer-based Short-circuit Protection with Auto-recovery or Latched Operation
- Latched OVP/OTP Input for Improved Robustness
- +0.9 A / -1.2 A Peak Source / Sink Drive Capability

The evaluation board needs to be plugged into an existing application. Below is a schematic example of a 120-W/12-V application with the NCP1252. The floating high-side MOSFET is driven thanks to a pulse transformer.

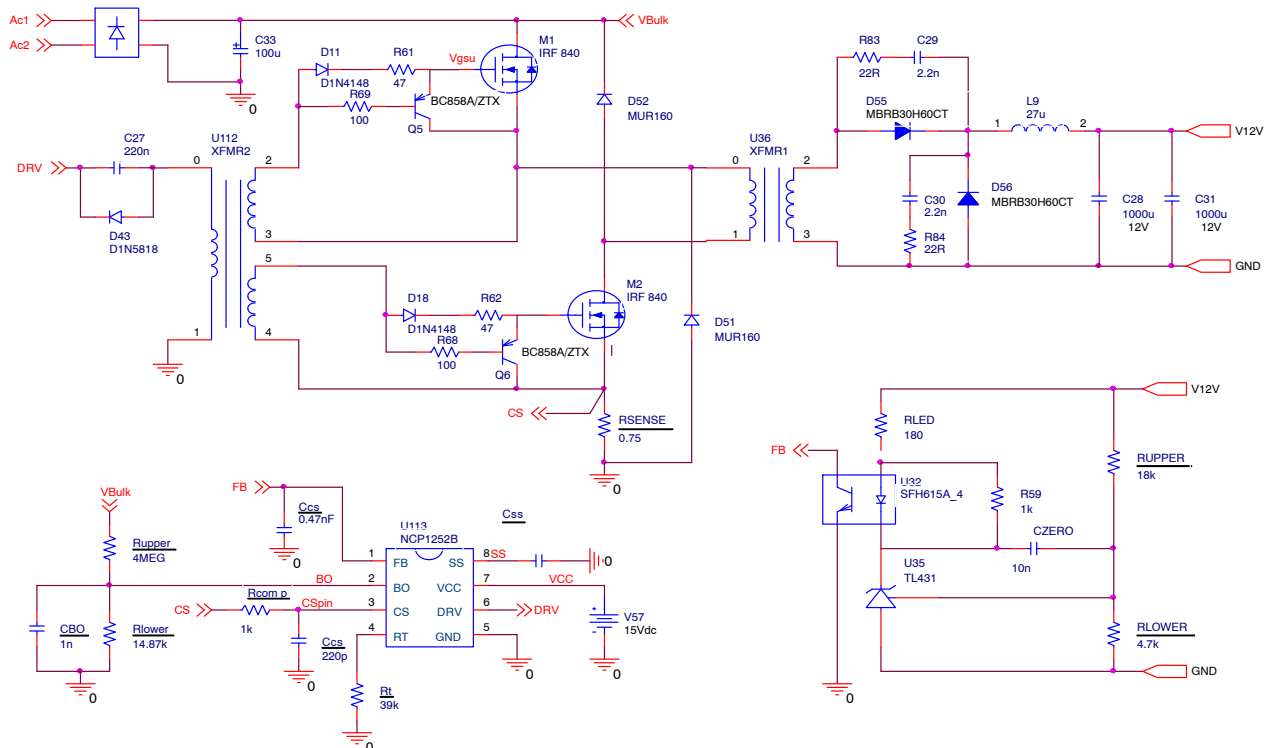

Figure 1. Application Schematic of the 120-W Adapter

Connection Diagram

In order to connect the daughter board, the old controller needs to be unsolder with the pulse transformer. Then the all tests points have to be connected to the main board with short connection. Of course, the ground (GND) node like the current sense (CS) and feedback (FB) connections have to be optimized first.

For the input voltage, it can be connected on the ac mains before the bridge diode or directly on the bulk capacitor.

If the previous schematic with the NCP1252 is modified, it will lead to the following arrangement shown in the Figure 2.

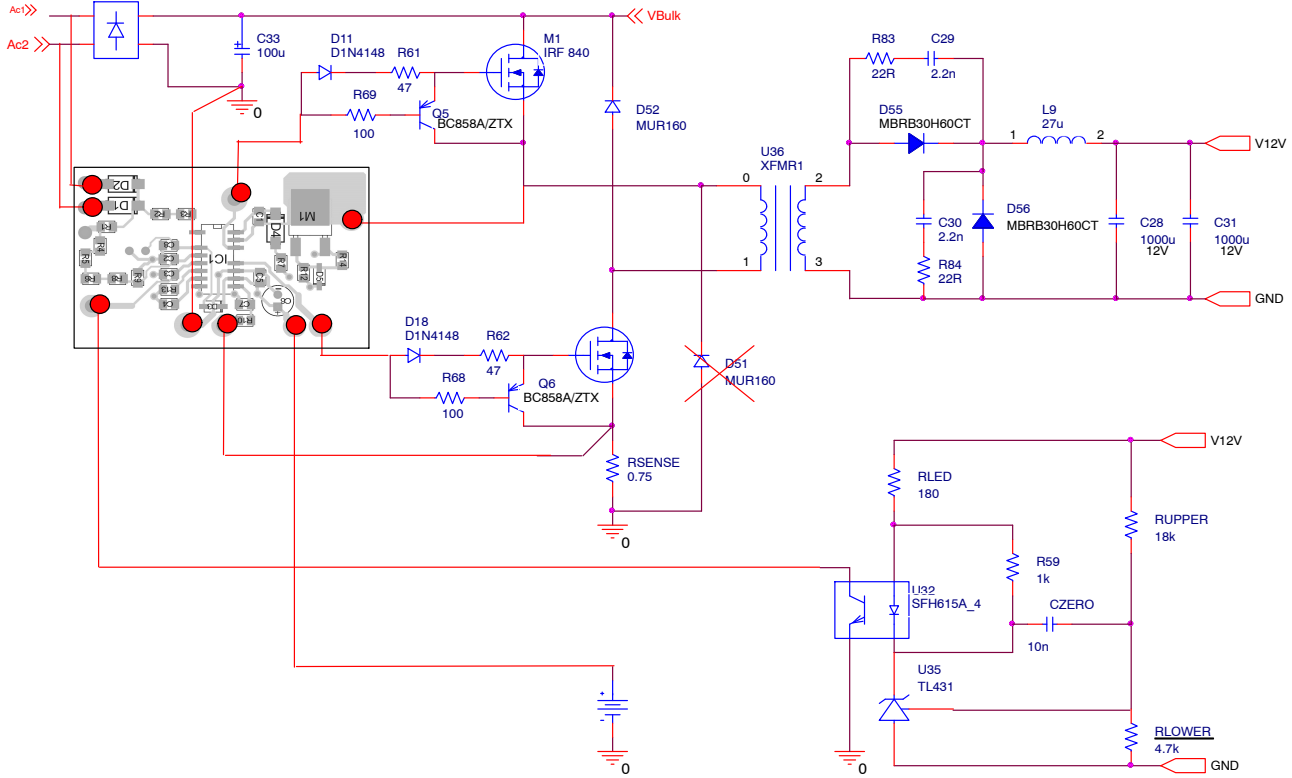

Figure 2. NCL30125 Daughter Board Inserted in the 120-W Application

Evaluation Board Schematic

The evaluation board has been designed to limit the external components. All needed parts are embedded into this daughter board. The BO thresholds can be adjusted with the resistors R₄, R₅, R₆, R₈ and R₉. The switching frequency can be changed thanks to the resistor R₁₃ and the soft-start duration via the capacitor C₄. Finally, the ramp compensation will be affected by the resistor R₁₀.

Please note that a 1-nF capacitor is placed close to the FB pin so the capacitor soldered on the power board needs to be removed to avoid compensation issue.

Finally, thanks to the MOSFET M₁ on the daughter board, the freewheel diode connected between the ground and the HB node can be removed on the mother board.

Layout

The PCB consists of a two layers FR4 board with 35 μm copper cladding. All components are soldered on the top side (only two through-hole components – NTC and V_{CC} capacitor).

All decoupling components as well as other small low-current devices (timing capacitors, feedback decoupling...) have been placed as close as possible to the control IC. The 3rd MOSFET M₁ used to refresh the bootstrap capacitor during the start-up and skip mode has to be placed as closed as possible to the high side driver in order to avoid large noise peak current. Short connections must be used between the HB pin and the drain and also between IC GND and source pin.

EVBUM2670

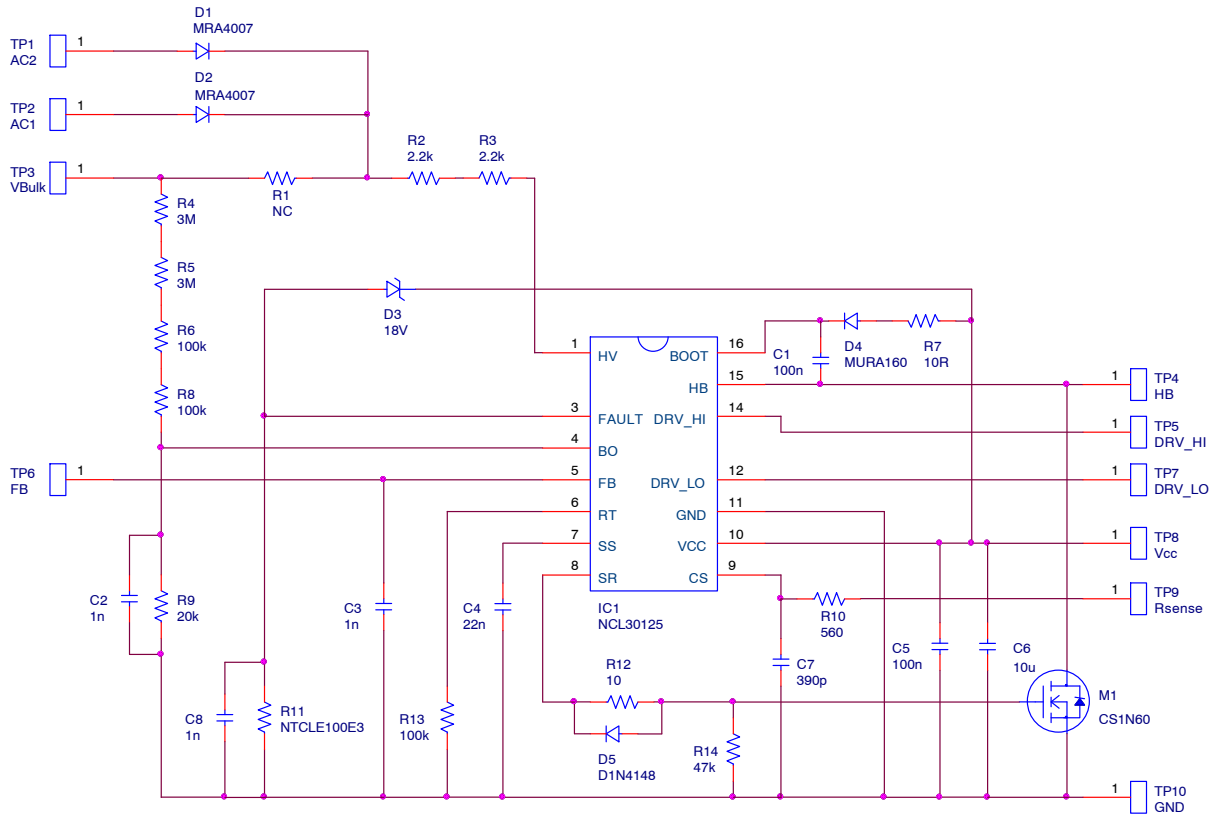

Figure 3. Daughter Board Schematic

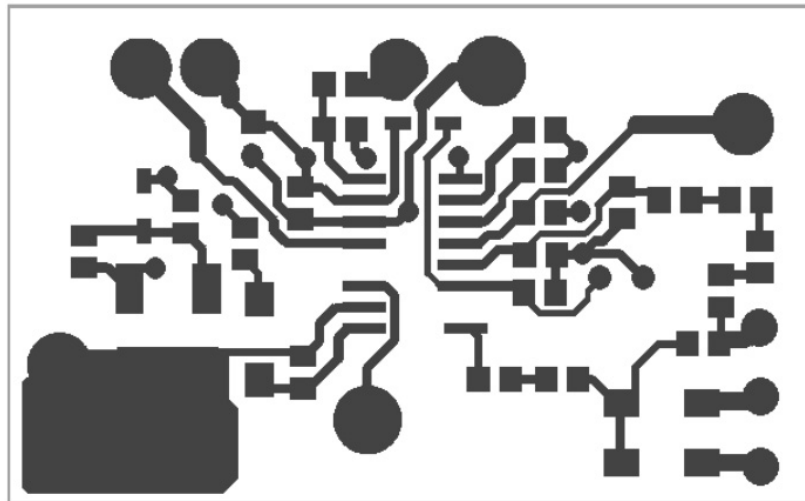

Figure 4. Top Layer

EVBUM2670

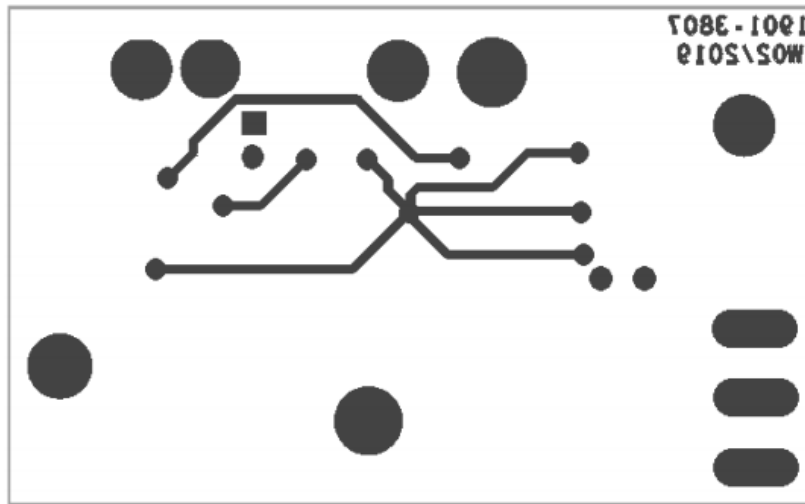

Figure 5. Bottom Layer

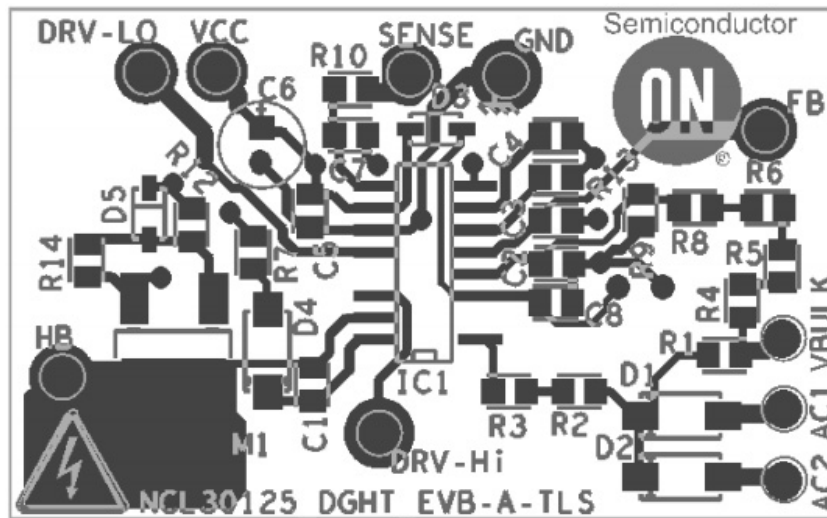

Figure 6. Top Side Components

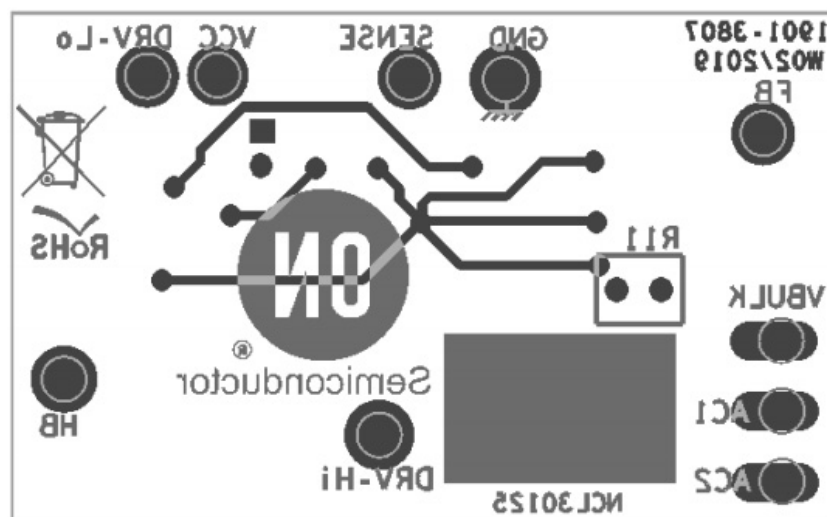

Figure 7. Bottom Side Components



Figure 8. Top Side Daughter Board Picture

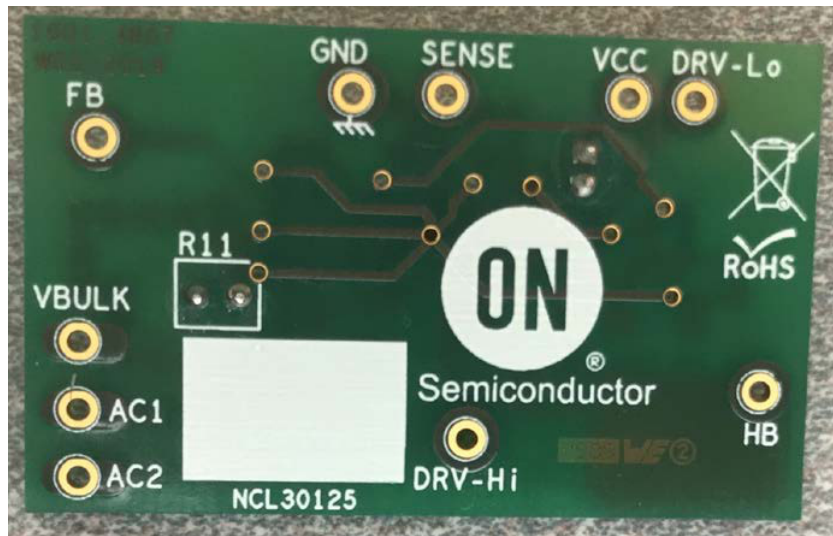

Figure 9. Bottom Side Daughter Board Picture

EVBUM2670

Table 1. BILL OF MATERIAL

| Designator | Quantity | Description | Value | Tolerance | Footprint | Manufacturer Part Number | Substitution Allowed |
|------------|----------|------------------------|----------------|--------------|--------------|--------------------------|----------------------|
| C1,C5 | 2 | Ceramic Capacitor | 100 nF | 10%, 50 V | 0805 | Standard | Yes |
| C2, C3, C8 | 3 | Ceramic Capacitor | 1 nF | 10%, 50 V | 0805 | Standard | Yes |
| C4 | 1 | Ceramic Capacitor | 22 nF | 10%, 50 V | 0805 | Standard | Yes |
| C6 | 1 | Electrolytic Capacitor | 10 μ F | 50 V | D5_H11_P2 | 860160672009 | Yes |
| C7 | 1 | Ceramic Capacitor | 390 pF | 10%, 50 V | 805 | Standard | Yes |
| D1, D2 | 2 | Power Rectifiers | MRA4007 | 1 A, 1 kV | SMA | ON Semiconductor | Yes |
| D3 | 1 | Zener Diode | 18 V | | SOD-123 | Standard | Yes |
| D4 | 1 | Power Rectifiers | MURA160 | 1 A, 600 V | SMA | MURA160T3G | Yes |
| D5 | 1 | Switching Diode | MMSD4148 | 100 V | SOD-123 | MMSD4148 | Yes |
| IC1 | 1 | Controller | | | SO-16 | NCL30125B1 | No |
| M1 | 1 | MOSFET | CS1N60 | 0.8 A, 600 V | TO-252 | CS1N60A4H | Yes |
| R1 | 1 | Ceramic Resistor | NC | 5% | 0805 | Standard | Yes |
| R2, R3 | 2 | Ceramic Resistor | 2.2 k Ω | 5% | 0805 | Standard | Yes |
| R4, R5 | 2 | Ceramic Resistor | 3 M Ω | 5% | 0805 | Standard | Yes |
| R6, R8 | 2 | Ceramic Resistor | 100 k Ω | 5% | 0805 | Standard | Yes |
| R7, R12 | 2 | Ceramic Resistor | 10 Ω | 5% | 0805 | Standard | Yes |
| R9 | 1 | Ceramic Resistor | 20 k Ω | 5% | 0805 | Standard | Yes |
| R10 | 1 | Ceramic Resistor | 560 Ω | 5% | 0805 | Standard | Yes |
| R11 | 1 | NTC, Beta = 4190 | 100 k @ 25°C | 5% | Through-hole | NTCLE100E3104JB0 | Yes |
| R13 | 1 | Ceramic Resistor | 100 k Ω | 5% | 0805 | Standard | Yes |
| R14 | 1 | Ceramic Resistor | 47 k Ω | 5% | 0805 | Standard | Yes |

onsemi, **Onsemi**, and other names, marks, and brands are registered and/or common law trademarks of Semiconductor Components Industries, LLC dba "**onsemi**" or its affiliates and/or subsidiaries in the United States and/or other countries. **onsemi** owns the rights to a number of patents, trademarks, copyrights, trade secrets, and other intellectual property. A listing of **onsemi**'s product/patent coverage may be accessed at www.onsemi.com/site/pdf/Patent-Marking.pdf. **onsemi** is an Equal Opportunity/Affirmative Action Employer. This literature is subject to all applicable copyright laws and is not for resale in any manner.

The evaluation board/kit (research and development board/kit) (hereinafter the "board") is not a finished product and is not available for sale to consumers. The board is only intended for research, development, demonstration and evaluation purposes and will only be used in laboratory/development areas by persons with an engineering/technical training and familiar with the risks associated with handling electrical/mechanical components, systems and subsystems. This person assumes full responsibility/liability for proper and safe handling. Any other use, resale or redistribution for any other purpose is strictly prohibited.

THE BOARD IS PROVIDED BY ONSEMI TO YOU "AS IS" AND WITHOUT ANY REPRESENTATIONS OR WARRANTIES WHATSOEVER. WITHOUT LIMITING THE FOREGOING, ONSEMI (AND ITS LICENSORS/SUPPLIERS) HEREBY DISCLAIMS ANY AND ALL REPRESENTATIONS AND WARRANTIES IN RELATION TO THE BOARD, ANY MODIFICATIONS, OR THIS AGREEMENT, WHETHER EXPRESS, IMPLIED, STATUTORY OR OTHERWISE, INCLUDING WITHOUT LIMITATION ANY AND ALL REPRESENTATIONS AND WARRANTIES OF MERCHANTABILITY, FITNESS FOR A PARTICULAR PURPOSE, TITLE, NON-INFRINGEMENT, AND THOSE ARISING FROM A COURSE OF DEALING, TRADE USAGE, TRADE CUSTOM OR TRADE PRACTICE.

onsemi reserves the right to make changes without further notice to any board.

You are responsible for determining whether the board will be suitable for your intended use or application or will achieve your intended results. Prior to using or distributing any systems that have been evaluated, designed or tested using the board, you agree to test and validate your design to confirm the functionality for your application. Any technical, applications or design information or advice, quality characterization, reliability data or other services provided by **onsemi** shall not constitute any representation or warranty by **onsemi**, and no additional obligations or liabilities shall arise from **onsemi** having provided such information or services.

onsemi products including the boards are not designed, intended, or authorized for use in life support systems, or any FDA Class 3 medical devices or medical devices with a similar or equivalent classification in a foreign jurisdiction, or any devices intended for implantation in the human body. You agree to indemnify, defend and hold harmless **onsemi**, its directors, officers, employees, representatives, agents, subsidiaries, affiliates, distributors, and assigns, against any and all liabilities, losses, costs, damages, judgments, and expenses, arising out of any claim, demand, investigation, lawsuit, regulatory action or cause of action arising out of or associated with any unauthorized use, even if such claim alleges that **onsemi** was negligent regarding the design or manufacture of any products and/or the board.

This evaluation board/kit does not fall within the scope of the European Union directives regarding electromagnetic compatibility, restricted substances (RoHS), recycling (WEEE), FCC, CE or UL, and may not meet the technical requirements of these or other related directives.

FCC WARNING – This evaluation board/kit is intended for use for engineering development, demonstration, or evaluation purposes only and is not considered by **onsemi** to be a finished end product fit for general consumer use. It may generate, use, or radiate radio frequency energy and has not been tested for compliance with the limits of computing devices pursuant to part 15 of FCC rules, which are designed to provide reasonable protection against radio frequency interference. Operation of this equipment may cause interference with radio communications, in which case the user shall be responsible, at its expense, to take whatever measures may be required to correct this interference.

onsemi does not convey any license under its patent rights nor the rights of others.

LIMITATIONS OF LIABILITY: **onsemi** shall not be liable for any special, consequential, incidental, indirect or punitive damages, including, but not limited to the costs of requalification, delay, loss of profits or goodwill, arising out of or in connection with the board, even if **onsemi** is advised of the possibility of such damages. In no event shall **onsemi**'s aggregate liability from any obligation arising out of or in connection with the board, under any theory of liability, exceed the purchase price paid for the board, if any.

The board is provided to you subject to the license and other terms per **onsemi**'s standard terms and conditions of sale. For more information and documentation, please visit www.onsemi.com.

ADDITIONAL INFORMATION

TECHNICAL PUBLICATIONS:

Technical Library: www.onsemi.com/design/resources/technical-documentation
onsemi Website: www.onsemi.com

ONLINE SUPPORT: www.onsemi.com/support

For additional information, please contact your local Sales Representative at www.onsemi.com/support/sales