

# ON Semiconductor

## Is Now

# onsemi™

To learn more about onsemi™, please visit our website at  
[www.onsemi.com](http://www.onsemi.com)

---

**onsemi** and **onsemi** and other names, marks, and brands are registered and/or common law trademarks of Semiconductor Components Industries, LLC dba "**onsemi**" or its affiliates and/or subsidiaries in the United States and/or other countries. **onsemi** owns the rights to a number of patents, trademarks, copyrights, trade secrets, and other intellectual property. A listing of **onsemi** product/patent coverage may be accessed at [www.onsemi.com/site/pdf/Patent-Marking.pdf](http://www.onsemi.com/site/pdf/Patent-Marking.pdf). **onsemi** reserves the right to make changes at any time to any products or information herein, without notice. The information herein is provided "as-is" and **onsemi** makes no warranty, representation or guarantee regarding the accuracy of the information, product features, availability, functionality, or suitability of its products for any particular purpose, nor does **onsemi** assume any liability arising out of the application or use of any product or circuit, and specifically disclaims any and all liability, including without limitation special, consequential or incidental damages. Buyer is responsible for its products and applications using **onsemi** products, including compliance with all laws, regulations and safety requirements or standards, regardless of any support or applications information provided by **onsemi**. "Typical" parameters which may be provided in **onsemi** data sheets and/or specifications can and do vary in different applications and actual performance may vary over time. All operating parameters, including "Typicals" must be validated for each customer application by customer's technical experts. **onsemi** does not convey any license under any of its intellectual property rights nor the rights of others. **onsemi** products are not designed, intended, or authorized for use as a critical component in life support systems or any FDA Class 3 medical devices or medical devices with a same or similar classification in a foreign jurisdiction or any devices intended for implantation in the human body. Should Buyer purchase or use **onsemi** products for any such unintended or unauthorized application, Buyer shall indemnify and hold **onsemi** and its officers, employees, subsidiaries, affiliates, and distributors harmless against all claims, costs, damages, and expenses, and reasonable attorney fees arising out of, directly or indirectly, any claim of personal injury or death associated with such unintended or unauthorized use, even if such claim alleges that **onsemi** was negligent regarding the design or manufacture of the part. **onsemi** is an Equal Opportunity/Affirmative Action Employer. This literature is subject to all applicable copyright laws and is not for resale in any manner. Other names and brands may be claimed as the property of others.

## Universal AC Input, 5.3 V 2 A Output, 10.6 W Charger Using NCP1360



ON Semiconductor®

[www.onsemi.com](http://www.onsemi.com)

### DESIGN NOTE

Table 1. DEVICE DETAILS

Device	Application	Input Voltage	Output Power	Topology	I/O Isolation
NCP1360BBCC NCP1360BCCC	Mobile, Tablet, Charger, Adapter	90 to 264 Vac	10.6 W	Quasi Resonant Flyback	Yes

Item	Output Specification	Test Condition
Rated Input Voltage	100 ~ 240 Vac	–
Input Voltage Range	90 ~ 264 Vac	–
Input Frequency Range	47 ~ 63 Hz	–
Inrush Current	< 30 A	264 Vac and 2 A Load
Average Efficiency	> 82%	Measured at Board End
Average Efficiency at Cable End	> 78%	Measured at Cable End
Standby Power	< 50 mW & 75 mW	90 ~ 264 Vac
Output Voltage	5 ~ 5.5 V, 5.3 V at 2 A	90 ~ 264 Vac and 0 ~ 2 A
Output Current	2 A	90 ~ 264 Vac
Rated Output Power	> 10.6 W	90 ~ 264 Vac
Ripple and Noise	< 120 mV	90 ~ 264 Vac, 1 $\mu$ F + 0.1 $\mu$ F CAP@E-load
Rise Time	< 30 ms	At No/Full Load, 115 Vac & 230 Vac
Start-up Time	< 1.5 s	90 ~ 264 Vac and 0 ~ 2 A
Over Shoot	< 6.4 V	At 1 m USB Cable End
Transient Response	4.5 ~ 5.5 V	0.1–1.9 A, 0.25 A/ $\mu$ s, 10 ms Cycle

#### Circuit Description

This design note describes a 10.6 W, universal AC input, isolated Quasi-Resonant flyback converter for smart phone, tablet charger and smart socket power supply etc.

The featured power supply is a primary side constant voltage and current regulation utilizing ON Semiconductor's new NCP1360 current mode controller which is in TSOP-6 package. This design note provides the complete circuit schematic details, layout, test data and BOM for 5.3 V, 2 A power supply.

Both NCP1360BBCC and NCP1360BCCC are all tested in this design, it has almost same performance except standby power and dynamic response.

#### 1. Input Circuit:

Rectifier, filter and EMC circuit formed by D1, C1, L1, NTC is 2.5  $\Omega$  negative temperature coefficient resistor to provide inrush protection, FR1 provides short-circuit protection when large AC input current occurs.

#### 2. NCP1360 Control Circuit:

R8 and R9 consists of voltage simple network to set output voltage, C12 is a delayed capacitor to delay switching on to valley.

R12 and R13 is a current sensing resistor to decide how much current can be set, R10 and CS pin parasitic capacitor consists of a filter to filter current spike. R19, C11 and C9 consist of a type II compensation network to provide voltage feedback

control loop compensation.

R5 and R11 is start-up resistor, two 7.5 MΩ are used in series to reduce power loss, R4, D6 and C4 consist of V<sub>CC</sub> supply circuit, R4 can adjust V<sub>CC</sub> voltage and also prevent D6 from an inrush current. An RCD–R clamp consisting of D5, R3, R6, and C7 limits drain voltage spikes caused by leakage inductance, resistor R6 has a relatively large value to prevent any excessive ringing on the drain voltage waveform and R3 can limit the reverse recovery current through D5.

3. Output Rectification and Filter:

The transformer (T1) secondary is rectified by D2, a Schottky barrier-type diode (chosen for higher efficiency), and filtered by C3, C5 and C8. In this application, C3 and C5 have sufficiently low ESR characteristics to allow meeting the output voltage ripple requirement without adding an LC post filter. C6 and R7 are snubber network of D2 to eliminate excessive ringing on secondary voltage waveform. R14 is a dummy load to prevent output voltage rising at no load.

**Key Features**

- Primary Side Regulation (PSR) CC/CV Control
- Quasi-Resonant Current Mode Control with Valley Switching
- Valley Lockout Avoids Audible Noise at Valley Jumping Operation
- Built in 4 ms Soft Start
- 110 kHz Maximum Clamp Frequency Operation
- Adjustable Voltage Control Loop Compensation
- 300 mV Cable Drop Compensation
- Wide Operation V<sub>CC</sub> Range (Up to 30 V)
- Cycle by Cycle Current Limit
- Support External 1500 μF Capacitive Load Start-up
- Built in V<sub>CC</sub> OVP (Typical 26 V)
- Built in Output UVP in CC Mode (3 V ±6.7%)
- Output OCP, SCP, OVP and Controller OTP Function
- CS Pin Open and Short Protection
- V<sub>s</sub> Pin Open and Short Protection
- Meet COC V5 Tier 2
- 100 pF Y Capacitor
- “Travel Adapter” (TA) Form Factor
- Size: 47 × 34 × 15 mm

**PCB Layout**

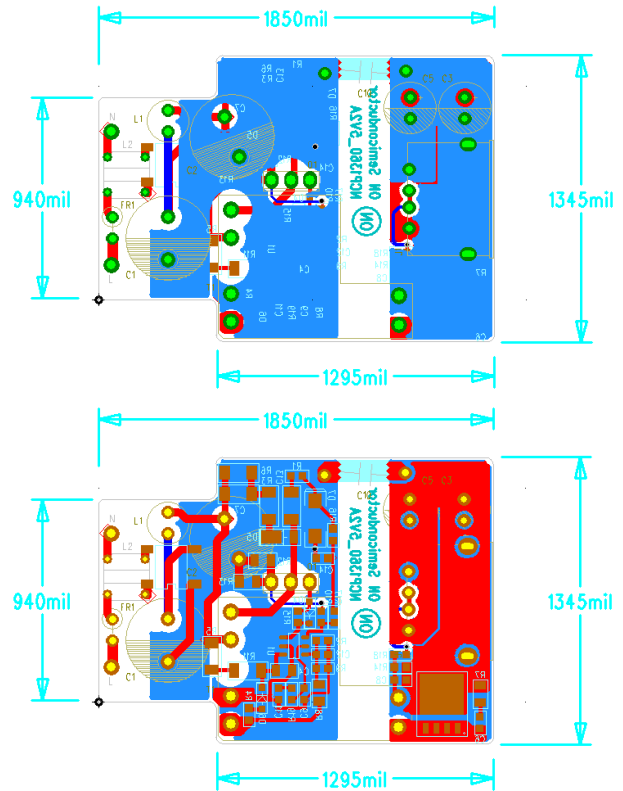

Figure 1. PCB Layout

**Demoboard Photo**

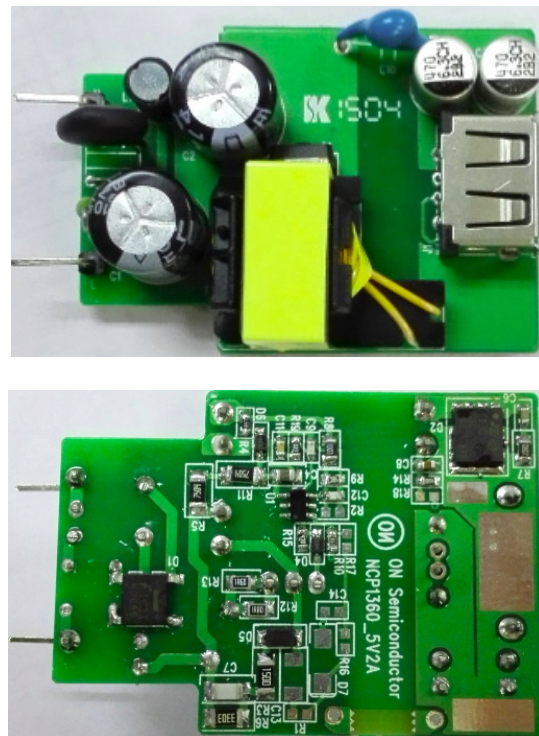

Figure 2. Demoboard Photo

Circuit Schematic

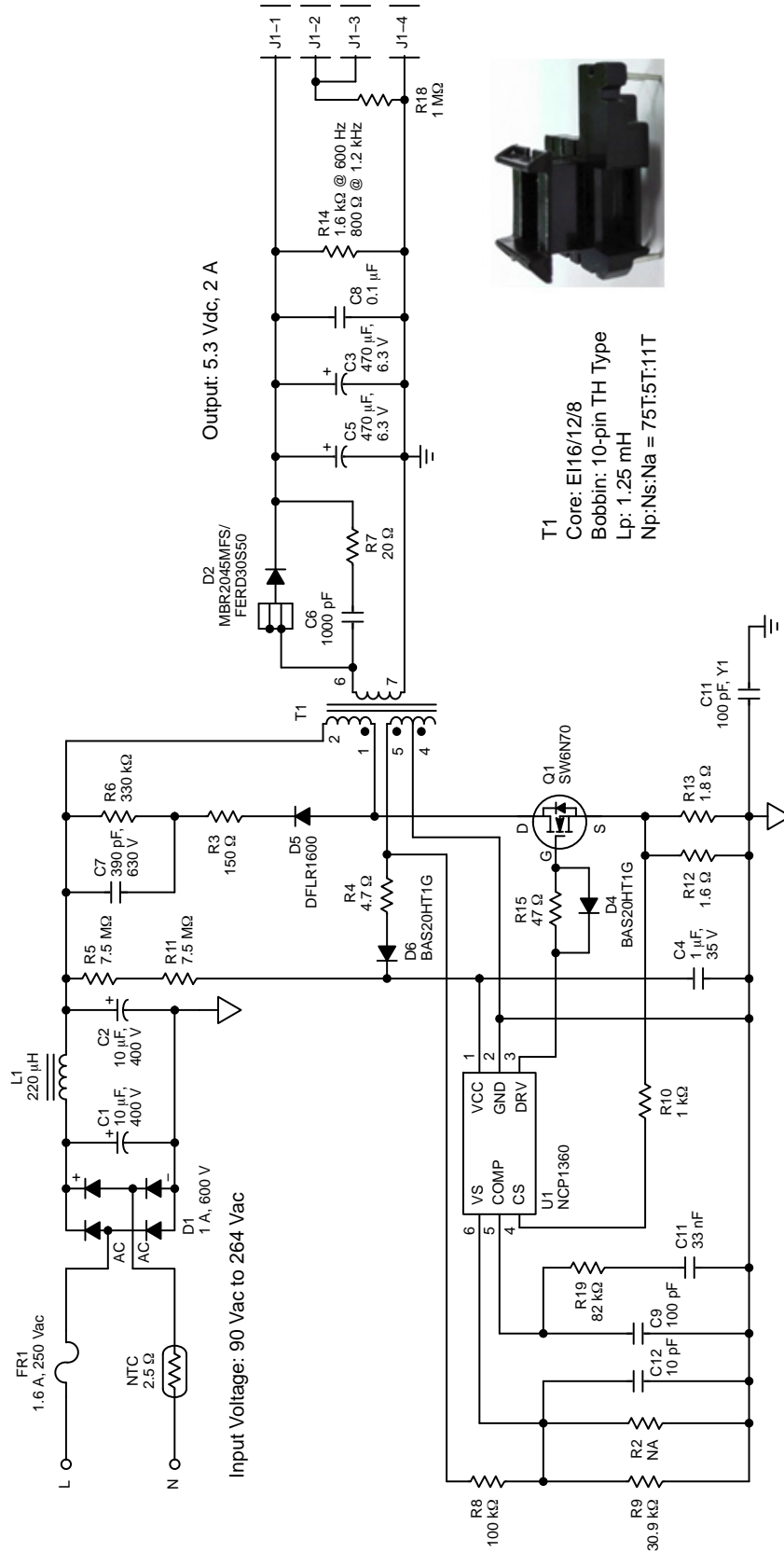

Figure 3. Circuit Schematic

Standby Power for NCP1360BBCC at No Load

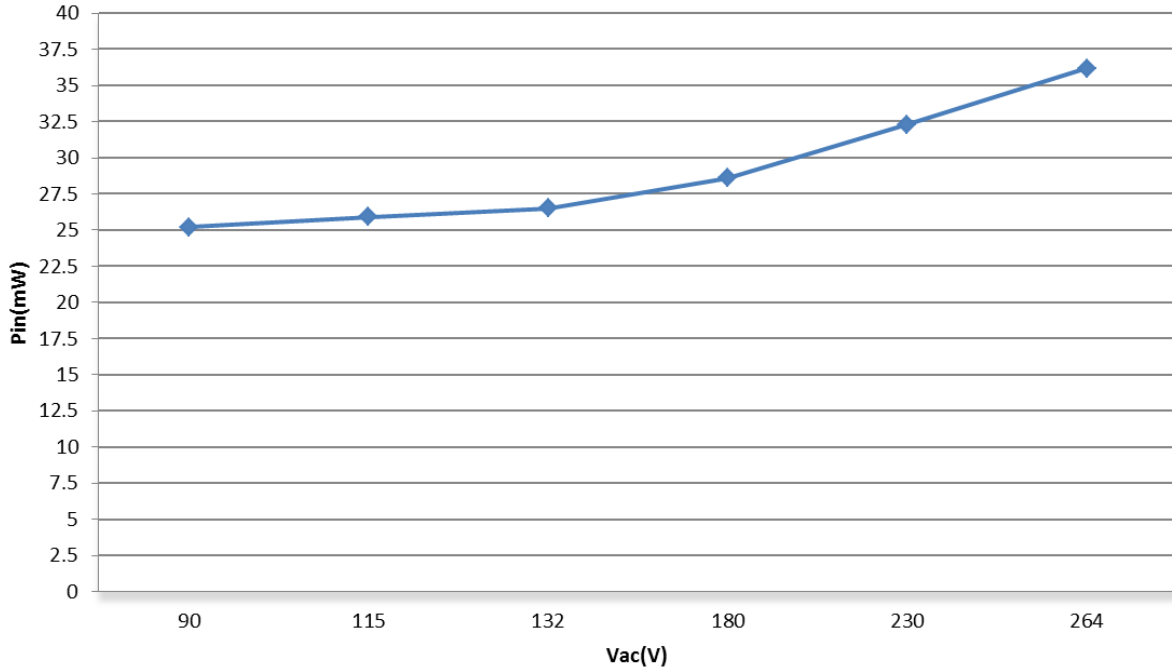

Figure 4. Standby Power for NCP1360BBCC at No Load

Standby Power for NCP1360BCCC at No Load

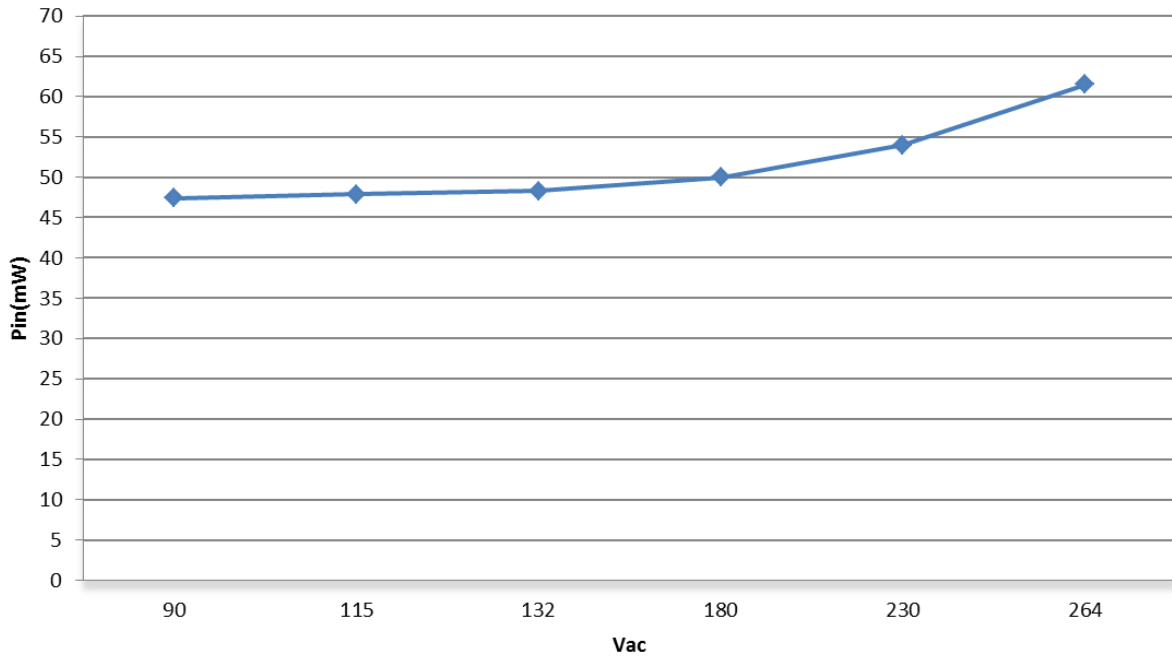

Figure 5. Standby Power for NCP1360BCCC at No Load

# DN05073/D

## Average Efficiency between 25%, 50%, 75% and 100% Load

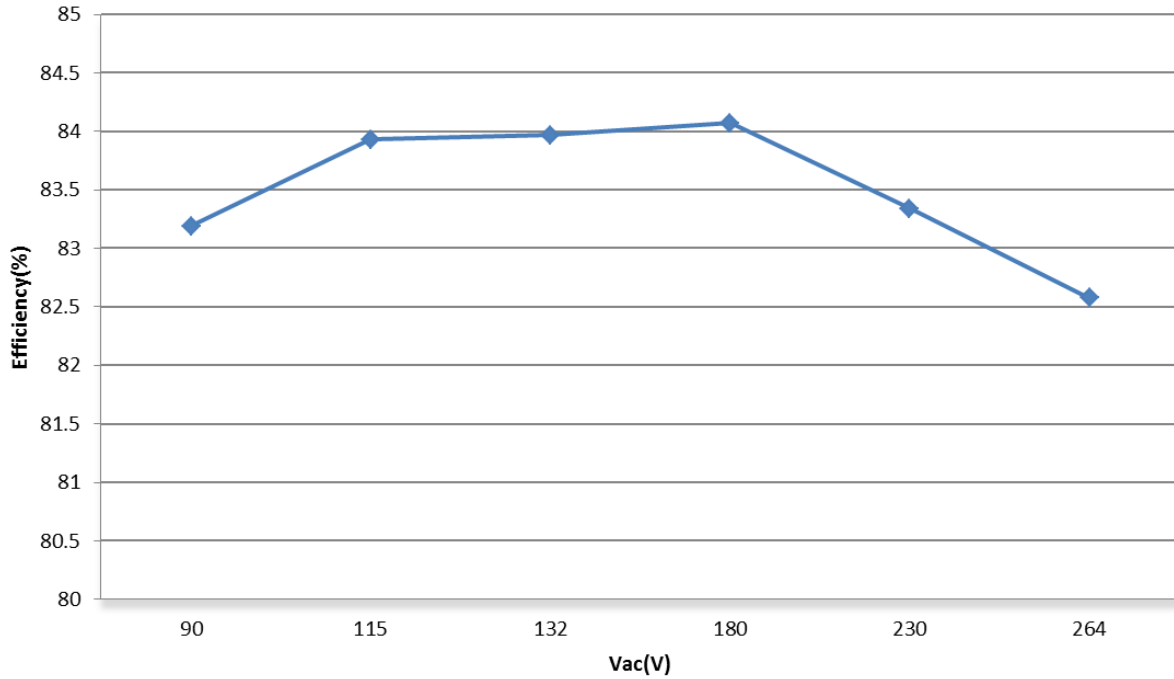

Figure 6. Average Efficiency between 25%, 50%, 75% and 100% Load

## Efficiency vs. Load Curves

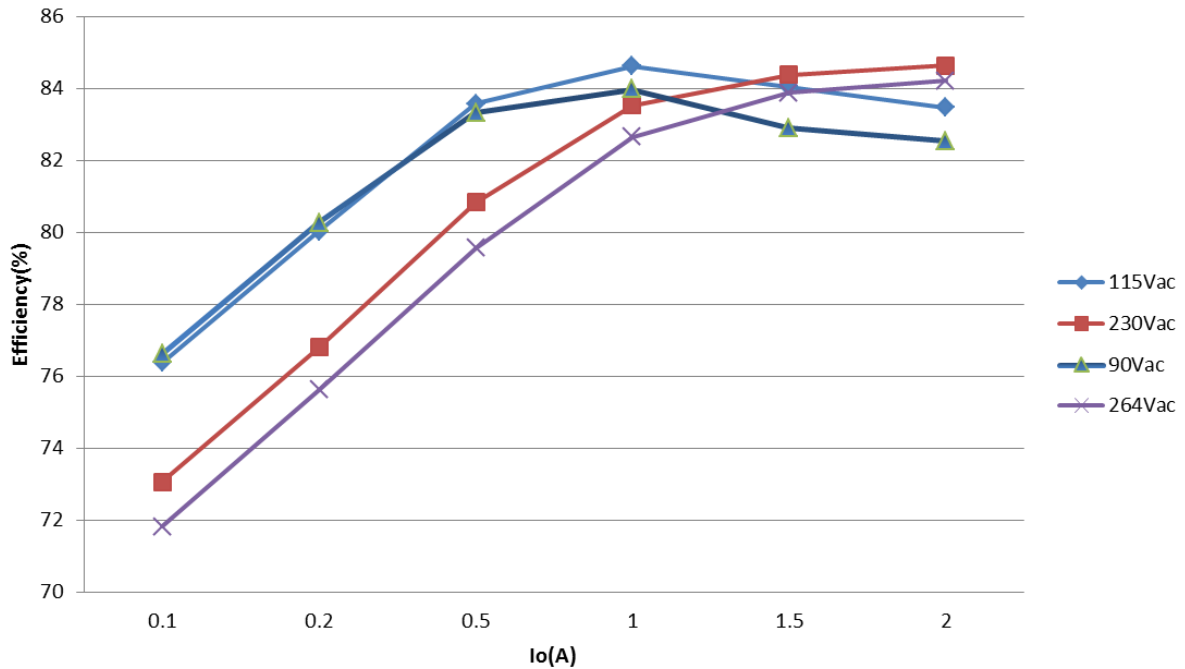

Figure 7. Efficiency vs. Load Curves

I-V Curves

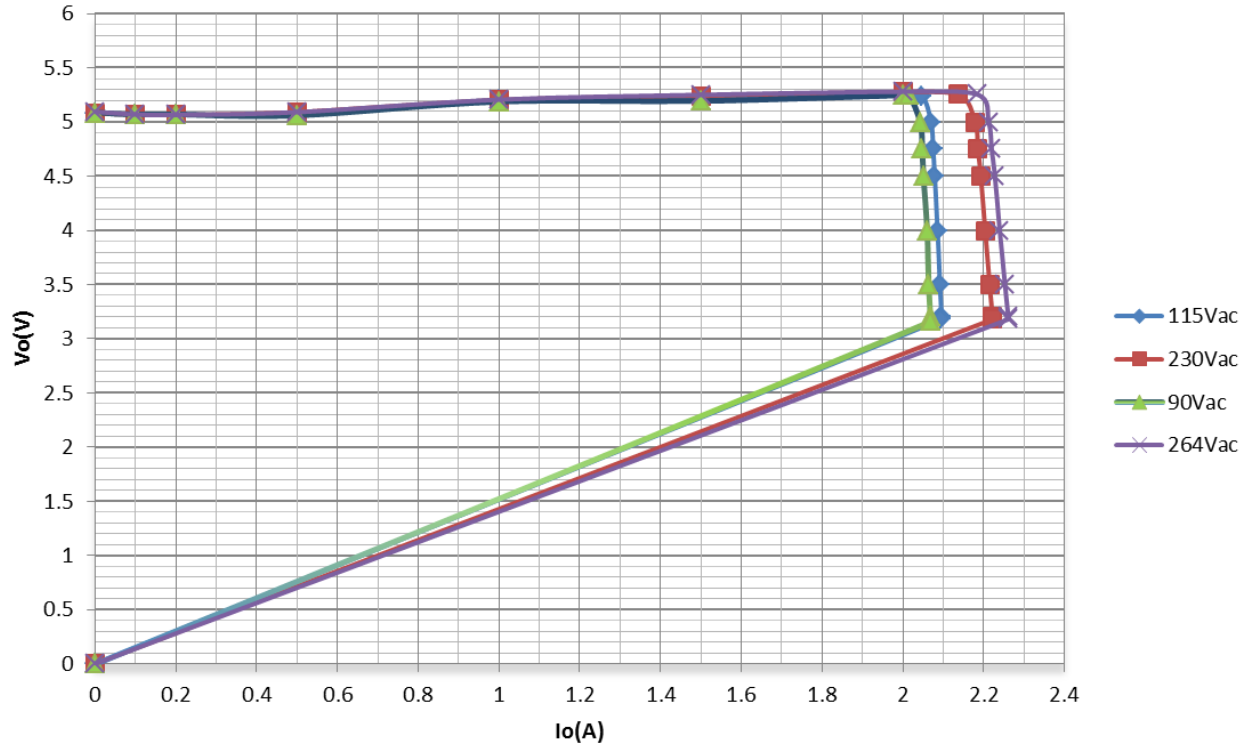

Figure 8. I-V Curves

OUTPUT RIPPLE VOLTAGE

(Test Condition: Tested at E-load with 1 m Cable, 1  $\mu$ F E-CAP and 0.1  $\mu$ F Ceramic in Parallel)

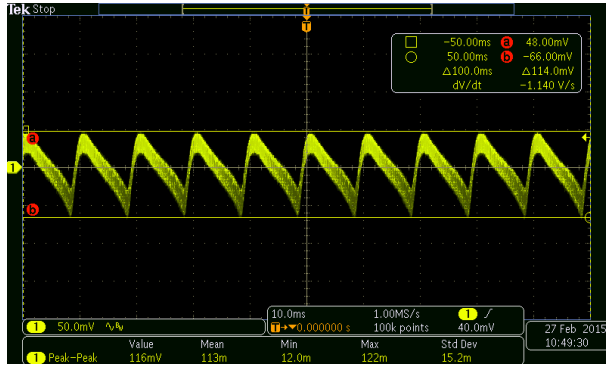

Figure 9. 90 Vac and 2 A Load

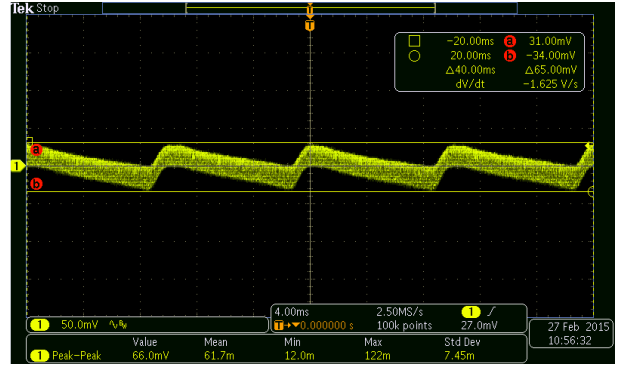

Figure 10. 115 Vac and 2 A Load

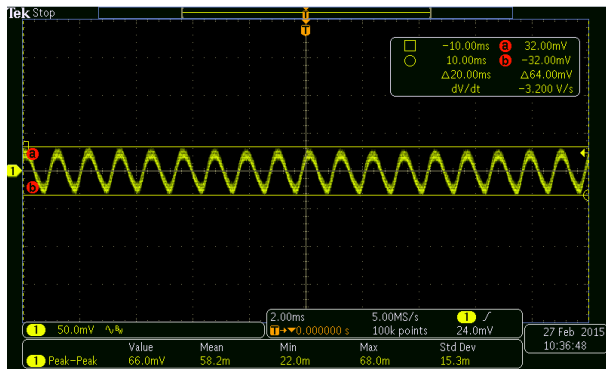

Figure 11. 230 Vac and 0.5 A Load

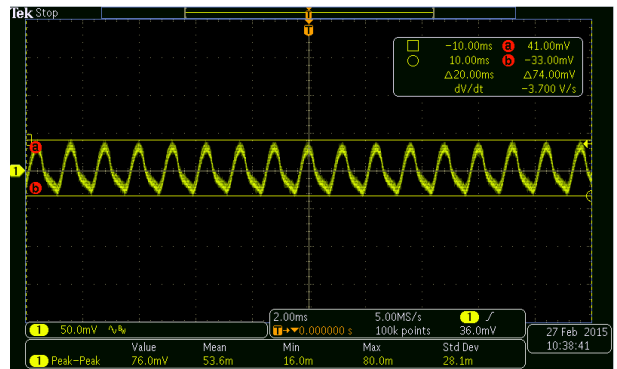

Figure 12. 264 Vac and 0.5 A Load

TRANSIENT RESPONSE FOR NCP1360BBCC



Figure 13. Test Conditions: 0.2–1.8 A, 250 mA/ $\mu$ s, 10 ms Cycle, 115 Vac

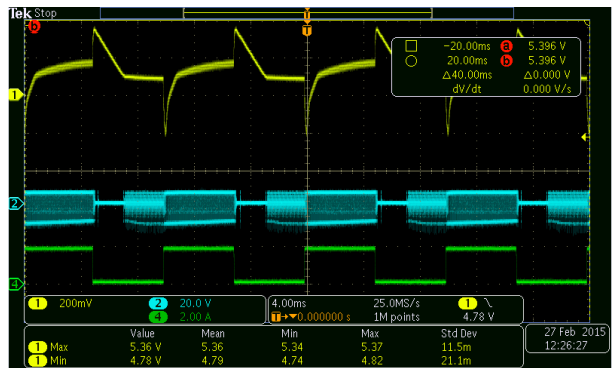

Figure 14. Test Conditions: 0.1–1.9 A, 250 mA/ $\mu$ s, 10 ms Cycle, 115 Vac



TRANSIENT RESPONSE FOR NCP1360BCCC

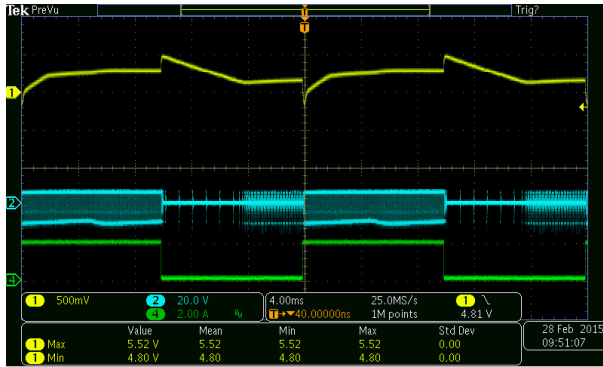

Figure 15. Test Conditions: 50 mA–2 A, 250 mA/μs, 20 ms Cycle, 115 Vac

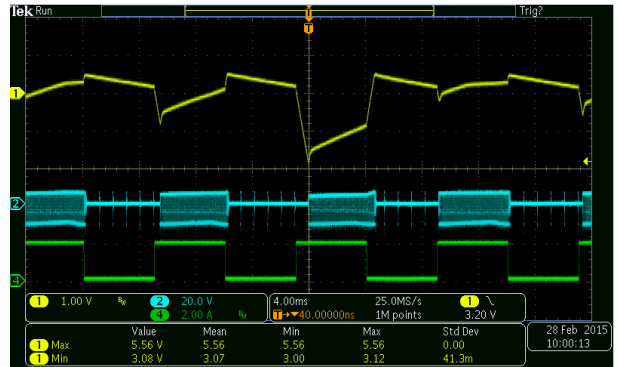

Figure 16. Test Conditions: 50 mA–2 A, 250 mA/μs, 10 ms Cycle, 115 Vac

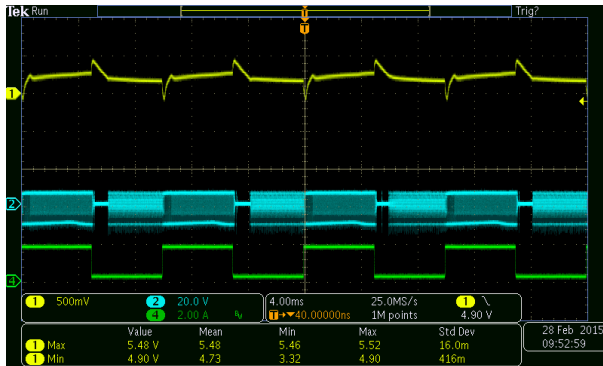

Figure 17. Test Conditions: 0.2–1.8 A, 250 mA/μs, 10 ms Cycle, 115 Vac

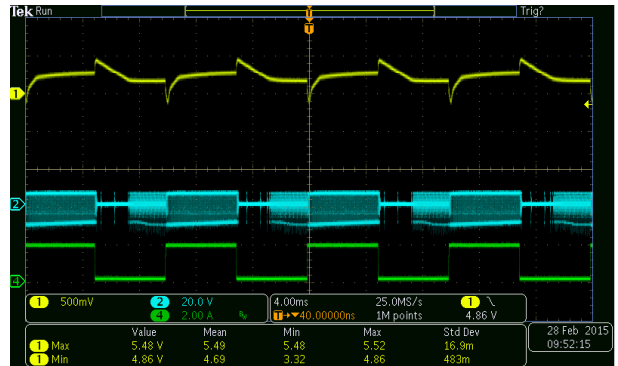

Figure 18. Test Conditions: 0.1–1.9 A, 250 mA/μs, 10 ms Cycle, 115 Vac

OVP AND SCP

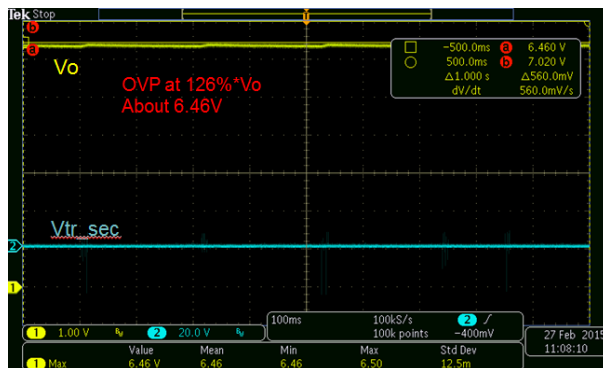

Figure 19. Test Conditions: 264 Vac, No Dummy Load

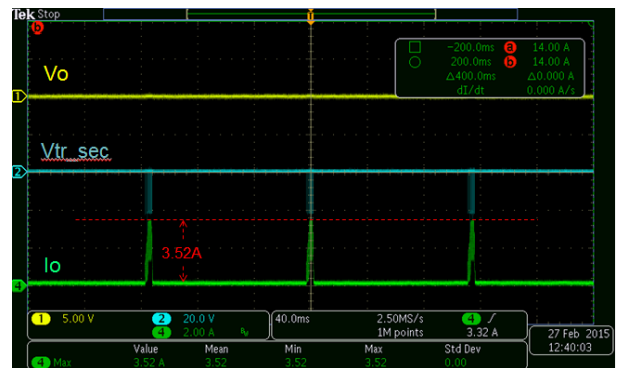

Figure 20. Test Conditions: SC at Board End

START-UP TIME

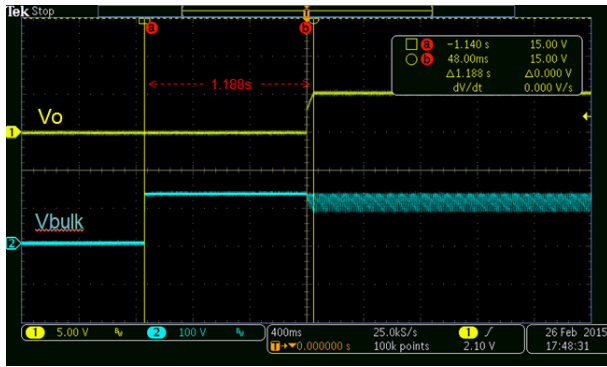

Figure 21. 90 Vac and 2 A CC Load

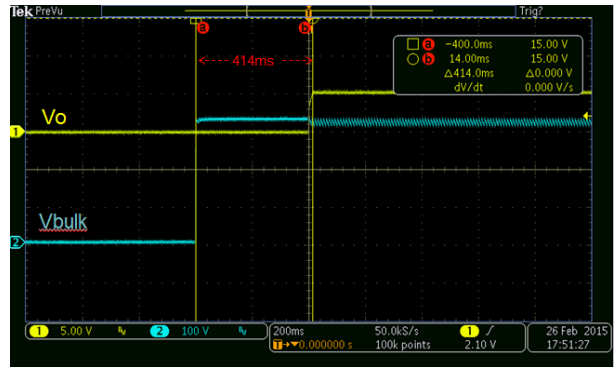

Figure 22. 230 Vac and 2 A CC Load

OUTPUT VOLTAGE RISE TIME

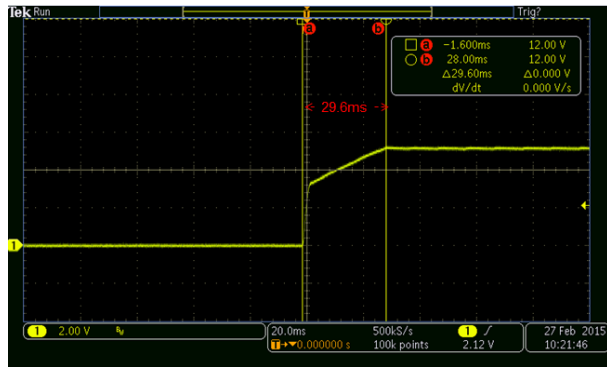

Figure 23. 115 Vac and 2 A CC Load

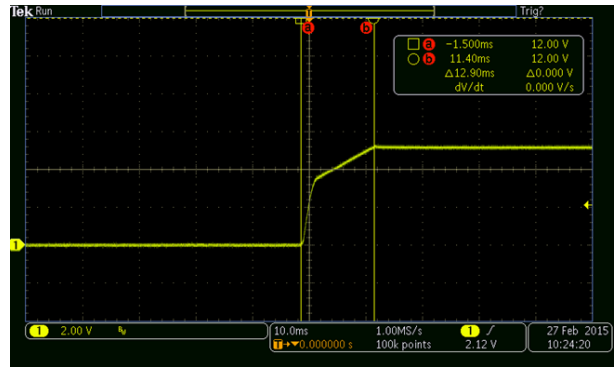

Figure 24. 230 Vac and 2 A CC Load

OUTPUT VOLTAGE OVERSHOOT

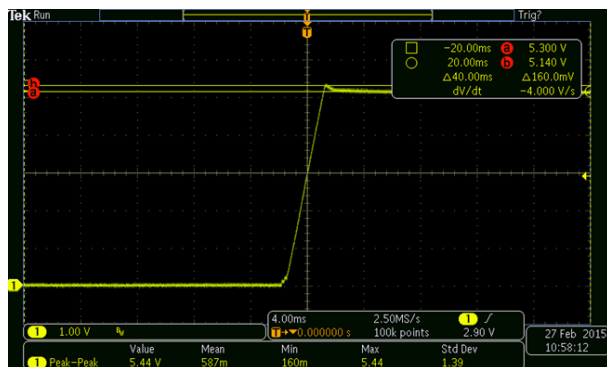

Figure 25. 115 Vac and No Load

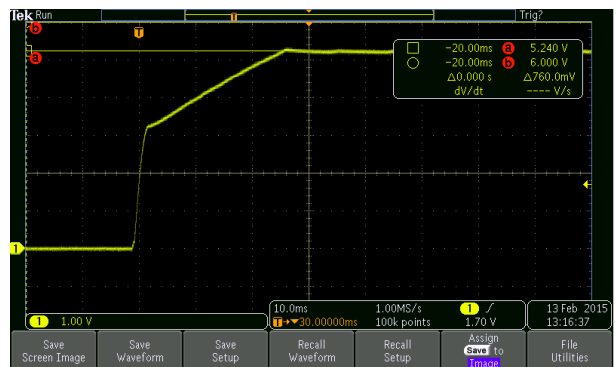

Figure 26. 115 Vac and 2 A CC Load

EXTERNAL 1500  $\mu$ F CAPACITIVE LOAD START-UP

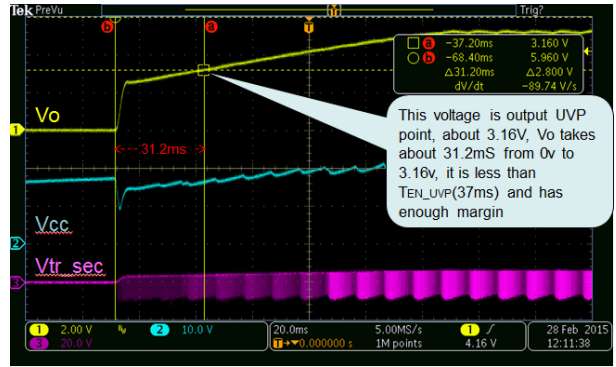
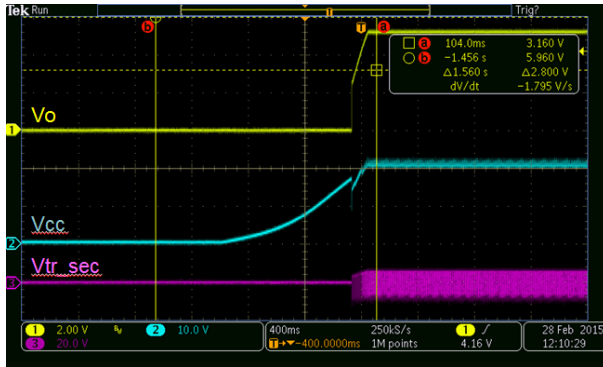

Figure 27. Test Conditions:Ext. 1500  $\mu$ F capacitor, 2 A CC Load with 1 V Von Voltage Set, 90 Vac

MOSFET DRAIN VOLTAGE

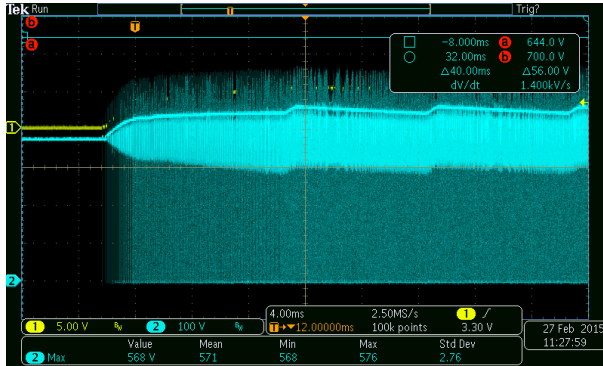

Figure 28. Startup at 264 Vac and 2 A CC Load

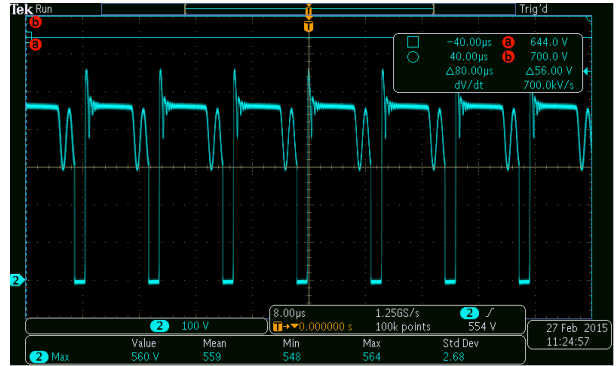

Figure 29. Working at 264 Vac and 2 A CC Load

INRUSH CURRENT

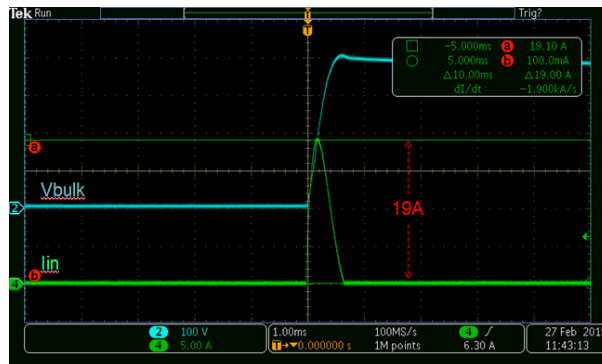

Figure 30. 264 Vac and 2 A CC Load

SECONDARY DIODE REVERSE VOLTAGE

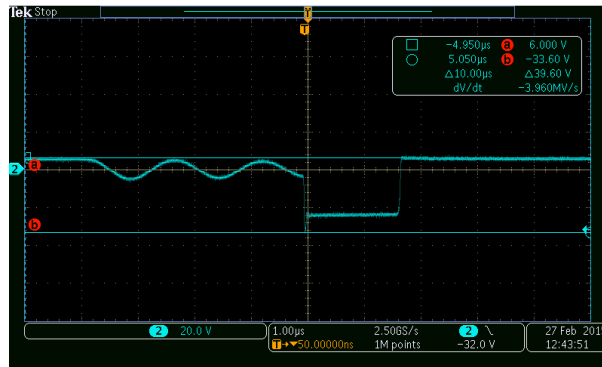

Figure 31. 264 Vac and 2 A CC Load

Bill of Material

Table 2. BILL OF MATERIAL

Items	Qty	Reference	Type	Part Number	Manufacturer	Value	Package	Description
1	1	C8	Ceramic	Std	Std	0.1 $\mu$ F, 50 V	603	Capacitor, Ceramic, 10%
2	1	C6	Ceramic	Std	Std	1000 pF, 50 V	603	Capacitor, Ceramic, 10%
3	1	C9	Ceramic	Std	Std	100 pF, 50 V	603	Capacitor, Ceramic, Chip, 10%
4	1	C10	Ceramic Capacitor	CS65-B2GA101KYNKA	TDK	100 pF, Y1	Lead Type	HV Ceramic Capacitor, Safety Standard Approved, 10%
5	1	C12	Ceramic	Std	Std	10 pF, 50 V	603	Capacitor, Ceramic, Chip, 10%
6	1	C4	Ceramic	C2012X7R1E105K	TDK	1 $\mu$ F, 35 V	805	Capacitor, Ceramic, Chip, 10%
7	1	C11	Ceramic	Std	Std	33 nF, 50 V	603	Capacitor, Ceramic, Chip, 10%
8	1	C7	Ceramic Capacitor	C3216C0G2J391J	TDK	390 pF, 630 V	1206	Capacitor, Ceramic, Chip, 5%
9	1	D1	Bridge Rectifier	LMB6S	FSC/Others	1 A, 600 V	Micro-DIP	Bridge Rectifier, 600 V, 1 A
10	1	D2	Schottky Rectifier	MBR2045MFS/FERD30S50	ON/ST	20 A, 45 V	SO8FL	Schottky Rectifier, 20 A, 45V/30 A, 50 V
11	1	D5	Standard Rectifier	DFLR1600	Diodes	1 A, 600 V	POWERD1123	Standard Rectifier, 1 A, 600 V
12	2	D4, D6	Switching Diode	BAS20HT1G	ON Semiconductor	0.2 A, 200 V	SOD323	Switching Diode, SMD
13	1	T1	Transformer	EI16/12/8	Customized Transformer		TH Type	Core: EI16/12/8, Customized Bobbin, 10-pin
14	1	FR1	Micro Fuse	20T-016H	HollyFUSE	1.6 A, 250 Vac	Radial Lead	Micro Fuse, 1.6 A/250 Vac, Radial Lead
15	1	U1	PSR Controller	NCP1360BBCC/BCCC	ON Semiconductor		TSOP-6	PSR Controller without HV Start-up Source, TSOP-6
16	1	Q1	NMOSFET	SW6N70	SAMWIN	6 A, 700 V	IPAK	NMOS, 6 A, 700 V, IPAK
17	1	NTC	NTC	SPNL07D2R5MBI	Sunlord	2.5 $\Omega$	Lead Type	NTC, 2.5 $\Omega$ , 3 A

Table 2. BILL OF MATERIAL (continued)

Items	Qty	Reference	Type	Part Number	Manufacturer	Value	Package	Description
18	1	L1	Fixed Inductor	7447462221	Würth	220 $\mu$ H	Lead Type	Axial Leaded Fixed Inductor
19	1	R8	Resistor	Std	Std	100 k $\Omega$	805	Resistor, Chip, 1/5 W, 1%
20	1	R10	Resistor	Std	Std	1 k $\Omega$	603	Resistor, Chip, 1/8 W, 1%
21	1	R9	Resistor	Std	Std	30.9 k $\Omega$	603	Resistor, Chip, 1/8 W, 1%
22	1	R4	Resistor	Std	Std	4.7 $\Omega$	603	Resistor, Chip, 1/8 W, 1%
23	1	R15	Resistor	Std	Std	47 $\Omega$	603	Resistor, Chip, 1/8 W, 1%
24	1	R19	Resistor	Std	Std	82 k $\Omega$	603	Resistor, Chip, 1/8 W, 1%
25	1	R2	Resistor	Std	Std	NA	603	Resistor, Chip, 1/8 W, 1%,
26	1	R12	Resistor	Std	Std	1.6 $\Omega$	805	Resistor, Chip, 1/5 W, 1%
27	1	R13	Resistor	Std	Std	1.8 $\Omega$	805	Resistor, Chip, 1/5 W, 1%
28	1	R3	Resistor	Std	Std	150 $\Omega$	1206	Resistor, Chip, 1/4 W, 1%
29	1	R7	Resistor	Std	Std	20 $\Omega$	805	Resistor, Chip, 1/5 W, 1%
30	1	R6	Resistor	Std	Std	330 k $\Omega$	1206	Resistor, Chip, 1/4 W, 1%
31	1	R14	Resistor	Std	Std	1.6 k $\Omega$ @ 600 Hz, 800 $\Omega$ @ 1.2 kHz	603	Resistor, Chip, 1/8 W, 1%
32	1	R18	Resistor	Std	Std	1 M $\Omega$	603	Resistor, Chip, 1/8 W, 1%
33	2	R5 R11	Resistor	Std	Std	7.5 M $\Omega$	1206	Resistor, Chip, 1/4 W, 1%
34	2	C1-2	Electrolytic Capacitor	AX/KSH106M400T1Z5H1CK	Rubycon/TEAPO	10 $\mu$ F,400 V	10 mm (Die.) $\times$ 12.5 mm (Height)	Size,10 $\times$ 12.5 mm
35	2	C3 C5	Electrolytic Solid Capacitor	PCH477M6R3S1AGE08K	TEAPO	470 $\mu$ F,6.3 V	6.3 mm (Die.) $\times$ 8mm (Height)	Aluminum Solid Capacitor, size, 6.3 $\times$ 8 mm

## References

- [1] DON Semiconductor datasheet for [NCP1360/5](#) CC/CV primary side PWM current mode controller.

ON Semiconductor and  are trademarks of Semiconductor Components Industries, LLC dba ON Semiconductor or its subsidiaries in the United States and/or other countries. ON Semiconductor owns the rights to a number of patents, trademarks, copyrights, trade secrets, and other intellectual property. A listing of ON Semiconductor's product/patent coverage may be accessed at [www.onsemi.com/site/pdf/Patent-Marking.pdf](http://www.onsemi.com/site/pdf/Patent-Marking.pdf). ON Semiconductor reserves the right to make changes without further notice to any products herein. ON Semiconductor makes no warranty, representation or guarantee regarding the suitability of its products for any particular purpose, nor does ON Semiconductor assume any liability arising out of the application or use of any product or circuit, and specifically disclaims any and all liability, including without limitation special, consequential or incidental damages. Buyer is responsible for its products and applications using ON Semiconductor products, including compliance with all laws, regulations and safety requirements or standards, regardless of any support or applications information provided by ON Semiconductor. "Typical" parameters which may be provided in ON Semiconductor data sheets and/or specifications can and do vary in different applications and actual performance may vary over time. All operating parameters, including "Typicals" must be validated for each customer application by customer's technical experts. ON Semiconductor does not convey any license under its patent rights nor the rights of others. ON Semiconductor products are not designed, intended, or authorized for use as a critical component in life support systems or any FDA Class 3 medical devices or medical devices with a same or similar classification in a foreign jurisdiction or any devices intended for implantation in the human body. Should Buyer purchase or use ON Semiconductor products for any such unintended or unauthorized application, Buyer shall indemnify and hold ON Semiconductor and its officers, employees, subsidiaries, affiliates, and distributors harmless against all claims, costs, damages, and expenses, and reasonable attorney fees arising out of, directly or indirectly, any claim of personal injury or death associated with such unintended or unauthorized use, even if such claim alleges that ON Semiconductor was negligent regarding the design or manufacture of the part. ON Semiconductor is an Equal Opportunity/Affirmative Action Employer. This literature is subject to all applicable copyright laws and is not for resale in any manner.

## PUBLICATION ORDERING INFORMATION

## LITERATURE FULFILLMENT:

Literature Distribution Center for ON Semiconductor  
19521 E. 32nd Pkwy, Aurora, Colorado 80011 USA  
Phone: 303-675-2175 or 800-344-3860 Toll Free USA/Canada  
Fax: 303-675-2176 or 800-344-3867 Toll Free USA/Canada  
Email: [orderlit@onsemi.com](mailto:orderlit@onsemi.com)

**N. American Technical Support:** 800-282-9855 Toll Free  
USA/Canada  
**Europe, Middle East and Africa Technical Support:**  
Phone: 421 33 790 2910  
**Japan Customer Focus Center**  
Phone: 81-3-5817-1050

**ON Semiconductor Website:** [www.onsemi.com](http://www.onsemi.com)

**Order Literature:** <http://www.onsemi.com/orderlit>

For additional information, please contact your local Sales Representative