

# ON Semiconductor

## Is Now

# onsemi™

To learn more about onsemi™, please visit our website at  
[www.onsemi.com](http://www.onsemi.com)

---

**onsemi** and **onsemi** and other names, marks, and brands are registered and/or common law trademarks of Semiconductor Components Industries, LLC dba "**onsemi**" or its affiliates and/or subsidiaries in the United States and/or other countries. **onsemi** owns the rights to a number of patents, trademarks, copyrights, trade secrets, and other intellectual property. A listing of **onsemi** product/patent coverage may be accessed at [www.onsemi.com/site/pdf/Patent-Marking.pdf](http://www.onsemi.com/site/pdf/Patent-Marking.pdf). **onsemi** reserves the right to make changes at any time to any products or information herein, without notice. The information herein is provided "as-is" and **onsemi** makes no warranty, representation or guarantee regarding the accuracy of the information, product features, availability, functionality, or suitability of its products for any particular purpose, nor does **onsemi** assume any liability arising out of the application or use of any product or circuit, and specifically disclaims any and all liability, including without limitation special, consequential or incidental damages. Buyer is responsible for its products and applications using **onsemi** products, including compliance with all laws, regulations and safety requirements or standards, regardless of any support or applications information provided by **onsemi**. "Typical" parameters which may be provided in **onsemi** data sheets and/or specifications can and do vary in different applications and actual performance may vary over time. All operating parameters, including "Typicals" must be validated for each customer application by customer's technical experts. **onsemi** does not convey any license under any of its intellectual property rights nor the rights of others. **onsemi** products are not designed, intended, or authorized for use as a critical component in life support systems or any FDA Class 3 medical devices or medical devices with a same or similar classification in a foreign jurisdiction or any devices intended for implantation in the human body. Should Buyer purchase or use **onsemi** products for any such unintended or unauthorized application, Buyer shall indemnify and hold **onsemi** and its officers, employees, subsidiaries, affiliates, and distributors harmless against all claims, costs, damages, and expenses, and reasonable attorney fees arising out of, directly or indirectly, any claim of personal injury or death associated with such unintended or unauthorized use, even if such claim alleges that **onsemi** was negligent regarding the design or manufacture of the part. **onsemi** is an Equal Opportunity/Affirmative Action Employer. This literature is subject to all applicable copyright laws and is not for resale in any manner. Other names and brands may be claimed as the property of others.

# MC1408-8

## 8-bit Multiplying D/A Converter

The MC1408-8 is an 8-bit monolithic digital-to-analog converter which provides high-speed performance with low cost. It is designed for use where the output current is a linear product of an 8-bit digital word and an analog reference voltage.

### Features

- Fast Settling Time: 70 ns (typ)
- Relative Accuracy  $\pm 0.19\%$  (max error)
- Non-inverting Digital Inputs are TTL and CMOS Compatible
- High-speed Multiplying Rate 4.0 mA/ $\mu$ s (Input Slew)
- Output Voltage Swing +0.5 V to -5.0 V
- Standard Supply Voltages +5.0 V and -5.0 V to -15 V
- Pb-Free Packages are Available\*

### Applications

- Tracking A-to-D Converters
- 2 1/2-Digit Panel Meters and DVMs
- Waveform Synthesis
- Sample-and-Hold
- Peak Detector
- Programmable Gain and Attenuation
- CRT Character Generation
- Audio Digitizing and Decoding
- Programmable Power Supplies
- Analog-Digital Multiplication
- Digital-Digital Multiplication
- Analog-Digital Division
- Digital Addition and Subtraction
- Speech Compression and Expansion
- Stepping Motor Drive Modems
- Servo Motor and Pen Drivers



**ON Semiconductor®**

<http://onsemi.com>

### MARKING DIAGRAMS

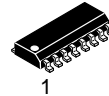

**SOIC-16**  
**D SUFFIX**  
**CASE 751B**

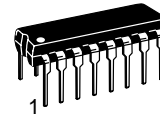

**PDIP-16**  
**N SUFFIX**  
**CASE 648**



A = Assembly Location  
WL = Wafer Lot  
YY, Y = Year  
WW = Work Week  
G = Pb-Free Package

### PIN CONNECTIONS

#### N Package

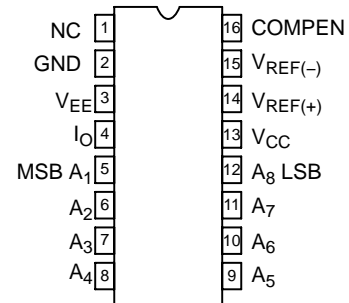

#### D Package\*

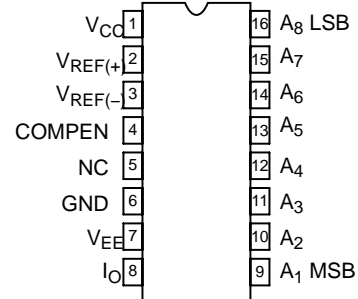

(Top View)

\*SO and non-standard pinouts.

\*For additional information on our Pb-Free strategy and soldering details, please download the ON Semiconductor Soldering and Mounting Techniques Reference Manual, SOLDERRM/D.

### ORDERING INFORMATION

See detailed ordering and shipping information in the package dimensions section on page 8 of this data sheet.

# MC1408-8

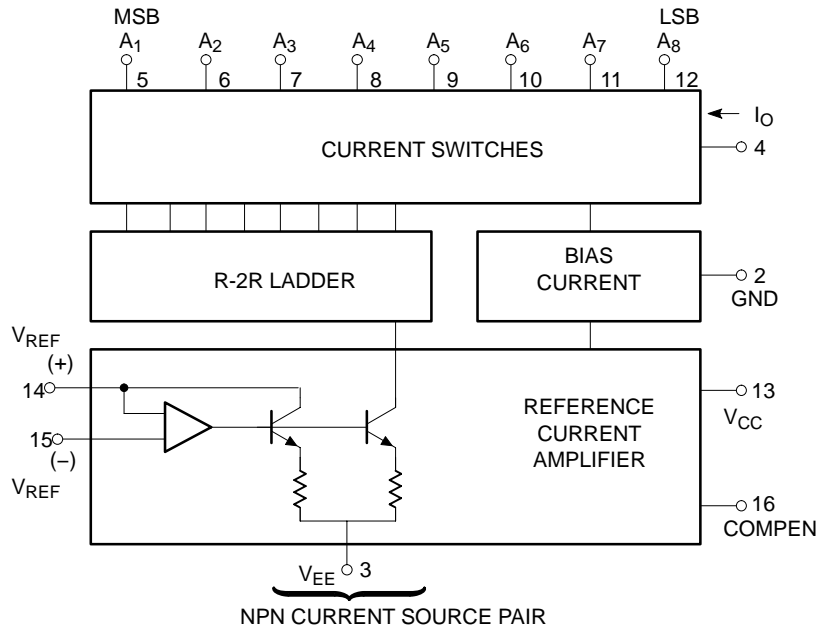

**Figure 1. Block Diagram**

## PIN FUNCTION DESCRIPTION

Pin N Package / D Package	Symbol	Description
1/5	NC	No Connect
2/6	GND	Ground
3/7	$V_{EE}$	Negative Power Supply
4/8	$I_o$	Output Current
5/9	A1	Output 1, Most Significant Bit (MSB)
6/10	A2	Output 2
7/11	A3	Output 3
8/12	A4	Output 4
9/13	A5	Output 5
10/14	A6	Output 6
11/15	A7	Output 7
12/16	A8	Output 8, Least Significant Bit (LSB)
13/1	$V_{CC}$	Positive Power Supply
14/2	$V_{REF(+)}$	Positive Reference Voltage
15/3	$V_{REF(-)}$	Negative Reference Voltage
16/4	COMPEN	Compensator Capacitor Pin

# MC1408-8

## MAXIMUM RATINGS

Rating	Symbol	Value	Unit
Positive Power Supply Voltage	$V_{CC}$	+5.5	V
Negative Power Supply Voltage	$V_{EE}$	-16.5	V
Digital Input Voltage	$V_5 - V_{12}$	0 to $V_{CC}$	V
Applied Output Voltage	$V_O$	-5.2 to +18	V
Reference Current	$I_{14}$	5.0	mA
Reference Amplifier Inputs	$V_{14}, V_{15}$	$V_{EE}$ to $V_{CC}$	
Maximum Power Dissipation, $T_{amb} = 25^\circ\text{C}$ (still-air) (Note 1) N Package D Package	$P_D$	1450 1080	mW
Thermal Resistance, Junction-to-Ambient N Package D Package	$R_{\theta JA}$	75 105	$^\circ\text{C/W}$
Operating Temperature Range	$T_{amb}$	0 to +75	$^\circ\text{C}$
Operating Junction Temperature	$T_J$	150	$^\circ\text{C}$
Storage Temperature Range	$T_{stg}$	-65 to +150	$^\circ\text{C}$
Lead Soldering Temperature (10 sec)	$T_{slid}$	+230	$^\circ\text{C}$

Stresses exceeding Maximum Ratings may damage the device. Maximum Ratings are stress ratings only. Functional operation above the Recommended Operating Conditions is not implied. Extended exposure to stresses above the Recommended Operating Conditions may affect device reliability.

- Derate above  $25^\circ\text{C}$ , at the following rates:  
N package at  $13.3 \text{ mW}/^\circ\text{C}$ ;  
D package at  $9.5 \text{ mW}/^\circ\text{C}$ .

## TYPICAL PERFORMANCE CHARACTERISTICS

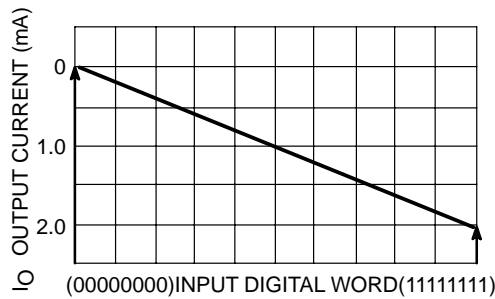

Figure 2. D-to-A Transfer Characteristics

# MC1408-8

**DC ELECTRICAL CHARACTERISTICS** (Pin 3 must be 3.0 V more negative than the potential to which R<sub>15</sub> is returned. V<sub>CC</sub> +5.0 V<sub>DC</sub>, V<sub>EE</sub> = -15 V<sub>DC</sub>, V<sub>REF</sub>/R<sub>14</sub> = 2.0 mA unless otherwise specified. T<sub>amb</sub> = 0°C to 75°C, unless otherwise noted.)

Characteristic	Test Conditions	Symbol	Min	Typ	Max	Unit
Relative Accuracy	Error relative to full-scale I <sub>O</sub> , Figure 5	E <sub>r</sub>			±0.19	%
Settling Time (Note 2)	To within 1/2 LSB, includes t <sub>PLH</sub> ; T <sub>amb</sub> = +25°C, Figure 6	t <sub>S</sub>		70		ns
Propagation Delay Time Low-to-High High-to-Low	T <sub>amb</sub> = +25°C, Figure 6	t <sub>PLH</sub> t <sub>PHL</sub>		35	100	ns
Output Full-scale Current Drift		TCl <sub>O</sub>		-20		ppm/°C
Digital Input Logic Level (MSB) High Low	Figure 7	V <sub>IH</sub> V <sub>IL</sub>	2.0		0.8	V <sub>DC</sub>
Digital Input Current (MSB) High Low	Figure 7 V <sub>IH</sub> = 5.0 V V <sub>IL</sub> = 0.8 V	I <sub>IH</sub> I <sub>IL</sub>		0 -0.4	0.04 -0.8	mA
Reference Input Bias Current	Pin 15, Figure 7	I <sub>15</sub>		-1.0	-5.0	μA
Output Current Range	Figure 7 V <sub>EE</sub> = -5.0 V V <sub>EE</sub> = -7.0 V to -15 V	I <sub>OR</sub>	0 0	2.0 2.0	2.1 4.2	mA
Output Current Off-State	Figure 7 V <sub>REF</sub> = 2.000 V, R <sub>14</sub> = 1000 Ω All bits low	I <sub>O</sub> I <sub>O(min)</sub>	1.9	1.99 0	2.1 4.0	mA μA
Output Voltage Compliance	E <sub>r</sub> ≤ 0.19%.0 at T <sub>A</sub> = +25°C, Figure 7 V <sub>EE</sub> = -5.0 V V <sub>EE</sub> below -10 V	V <sub>O</sub>		-0.6 +10 -5.5, +10	-0.55, +0.5 -5.0, +0.5	V <sub>DC</sub>
Reference Current Slew Rate	Figure 8	SRI <sub>REF</sub>		8.0		mA/μs
Output Current Power Supply Sensitivity	I <sub>REF</sub> = 1.0 mA	PSRR(-)		0.5	2.7	μA/V
Power Supply Current Positive Negative	All bits low, Figure 7	I <sub>CC</sub> I <sub>EE</sub>		+2.5 -6.5	+22 -13	mA
Power Supply Voltage Range Positive Negative	T <sub>amb</sub> = +25°C, Figure 7	V <sub>CCR</sub> V <sub>EER</sub>	+4.5 -4.5	+5.0 -15	+5.5 -16.5	V <sub>DC</sub>
Power Dissipation	All bits low, Figure 7 V <sub>EE</sub> = -5.0 V <sub>DC</sub> V <sub>EE</sub> = -15.0 V <sub>DC</sub>	P <sub>D</sub>		34 110	170 305	mW

2. All bits switched.

**Circuit Description**

The MC1408-8 consists of a reference current amplifier, an R-2R ladder, and 8 high-speed current switches. For many applications, only a reference resistor and reference voltage need be added.

The switches are non-inverting in operation; therefore, a high state on the input turns on the specified output current component.

The switch uses current steering for high speed, and a termination amplifier consisting of an active load gain stage with unity gain feedback. The termination amplifier holds the parasitic capacitance of the ladder at a constant voltage during switching, and provides a low impedance termination of equal voltage for all legs of the ladder.

The R-2R ladder divides the reference amplifier current into binary-related components, which are fed to the remainder current which is equal to the least significant bit. This current is shunted to ground, and the maximum output current is 255/256 of the reference amplifier current, or 1.992 mA for a 2.0 mA reference amplifier current if the NPN current source pair is perfectly matched.

**Functional Description**

**Reference Amplifier Drive and Compensation**

The reference amplifier input current must always flow into Pin 14, regardless of the setup method or reference supply voltage polarity.

Connections for a positive reference voltage are shown in Figure 3. The reference voltage source supplies the full reference current. For bipolar reference signals, as in the multiplying mode, R<sub>15</sub> can be tied to a negative voltage

corresponding to the minimum input level. R<sub>15</sub> may be eliminated and Pin 15 grounded, with only a small sacrifice in accuracy and temperature drift.

The compensation capacitor value must be increased with increasing values of R<sub>14</sub> to maintain proper phase margin. For R<sub>14</sub> values of 1.0, 2.5, and 5.0 kΩ, minimum capacitor values are 15, 37, and 75 pF. The capacitor may be tied to either V<sub>EE</sub> or ground, but using V<sub>EE</sub> increases negative supply rejection. (Fluctuations in the negative supply have more effect on accuracy than do any changes in the positive supply.)

A negative reference voltage may be used if R<sub>14</sub> is grounded and the reference voltage is applied to R<sub>15</sub>, as shown in Figure 4. A high input impedance is the main advantage of this method. The negative reference voltage must be at least 3.0 V above the V<sub>EE</sub> supply. Bipolar input signals may be handled by connecting R<sub>14</sub> to a positive reference voltage equal to the peak positive input level at Pin 15.

Capacitive bypass to ground is recommended when a DC reference voltage is used. The 5.0 V logic supply is not recommended as a reference voltage, but if a well regulated 5.0 V supply which drives logic is to be used as the reference, R<sub>14</sub> should be formed of two series resistors and the junction of the two resistors bypassed with 0.1 μF to ground. For reference voltages greater than 5.0 V, a clamp diode is recommended between Pin 14 and ground.

If Pin 14 is driven by a high impedance such as a transistor current source, none of the above compensation methods apply and the amplifier must be heavily compensated, decreasing the overall bandwidth.

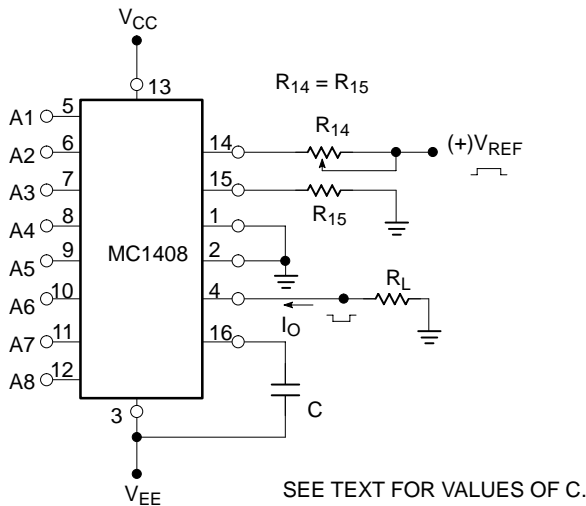

**Figure 3. Positive V<sub>REF</sub>**

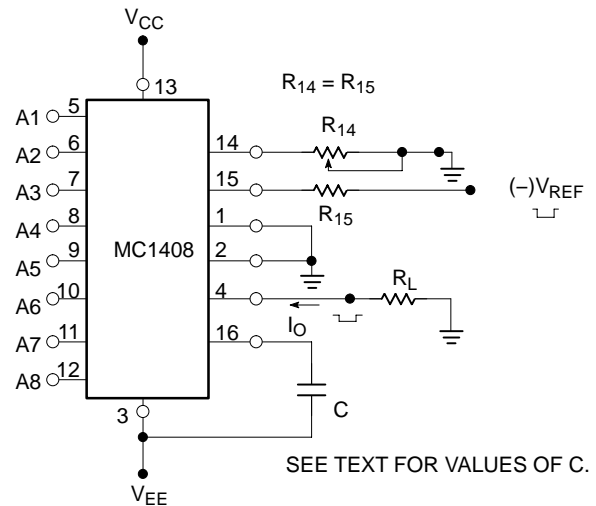

**Figure 4. Negative V<sub>REF</sub>**

# MC1408-8

## Output Voltage Range

The voltage at Pin 4 must always be at least 4.5 V more positive than the voltage of the negative supply (Pin 3) when the reference current is 2.0 mA or less, and at least 8 V more positive than the negative supply when the reference current is between 2.0 mA and 4.0 mA. This is necessary to avoid saturation of the output transistors, which would cause serious degradation of accuracy.

ON Semiconductor's MC1408-8 does not need a range control because the design extends the compliance range down to 4.5 V (or 8.0 V—see above) above the negative supply voltage without significant degradation of accuracy. ON Semiconductor's MC1408-8 can be used in sockets designed for other manufacturers' MC1408 without circuit modification.

## Output Current Range

Any time the full-scale current exceeds 2.0 mA, the negative supply must be at least 8.0 V more negative than the output voltage. This is due to the increased internal voltage drops between the negative supply and the outputs with higher reference currents.

## Accuracy

Absolute accuracy is the measure of each output current level with respect to its intended value, and is dependent upon relative accuracy, full-scale accuracy and full-scale

current drift. Relative accuracy is the measure of each output current level as a fraction of the full-scale current after zero-scale current has been nulled out. The relative accuracy of the MC1408-8 is essentially constant over the operating temperature range because of the excellent temperature tracking of the monolithic resistor ladder. The reference current may drift with temperature, causing a change in the absolute accuracy of output current; however, the MC1408-8 has a very low full-scale current drift over the operating temperature range.

The MC1408-8 series is guaranteed accurate to within  $\pm 1/2$  LSB at +25 °C at a full-scale output current of 1.99 mA. The relative accuracy test circuit is shown in Figure 5. The 12-bit converter is calibrated to a full-scale output current of 1.99219 mA; then the MC1408-8's full-scale current is trimmed to the same value with  $R_{14}$  so that a zero value appears at the error amplifier output. The counter is activated and the error band may be displayed on the oscilloscope, detected by comparators, or stored in a peak detector.

Two 8-bit D-to-A converters may not be used to construct a 16-bit accurate D-to-A converter. 16-bit accuracy implies a total of  $\pm 1/2$  part in 65,536, or  $\pm 0.00076\%$ , which is much more accurate than the  $\pm 0.19\%$  specification of the MC1408-8.

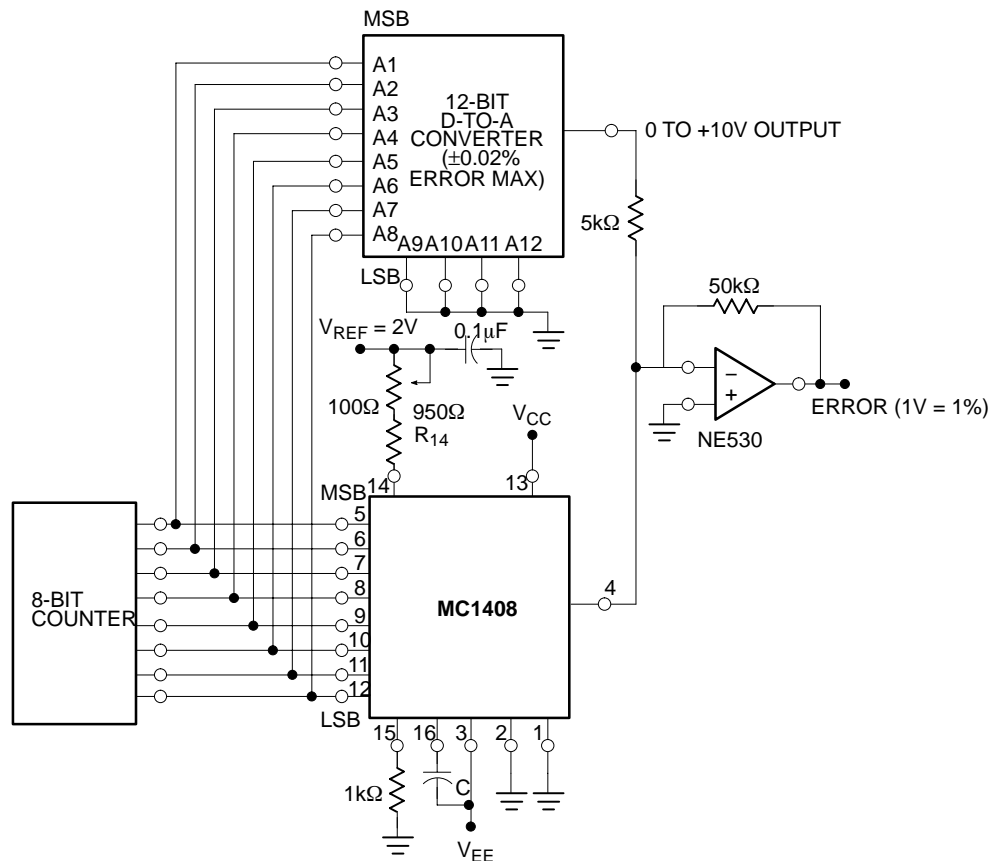

Figure 5. Relative Accuracy

# MC1408-8

## Monotonicity

A monotonic converter is one which always provides an analog output greater than or equal to the preceding value for a corresponding increment in the digital input code. The MC1408-8 is monotonic for all values of reference current above 0.5 mA. The recommended range for operation is a DC reference current between 0.5 mA and 4.0 mA.

## Settling Time

The worst case switching condition occurs when all bits are switched on, which corresponds to a low-to-high transition for all input bits. This time is typically 70 ns for settling to within 1/2LSB for 8-bit accuracy. This time

applies when  $R_L < 500 \Omega$  and  $C_O < 25 \text{ pF}$ . The slowest single switch is the least significant bit, which typically turns on and settles in 65 ns. In applications where the D-to-A converter functions in a positive going ramp mode, the worst-case condition does not occur and settling times less than 70 ns may be realized.

Extra care must be taken in board layout since this usually is the dominant factor in satisfactory test results when measuring settling time. Short leads, 100  $\mu\text{F}$  supply bypassing for low frequencies, minimum scope lead length, good ground planes, and avoidance of ground loops are all mandatory.

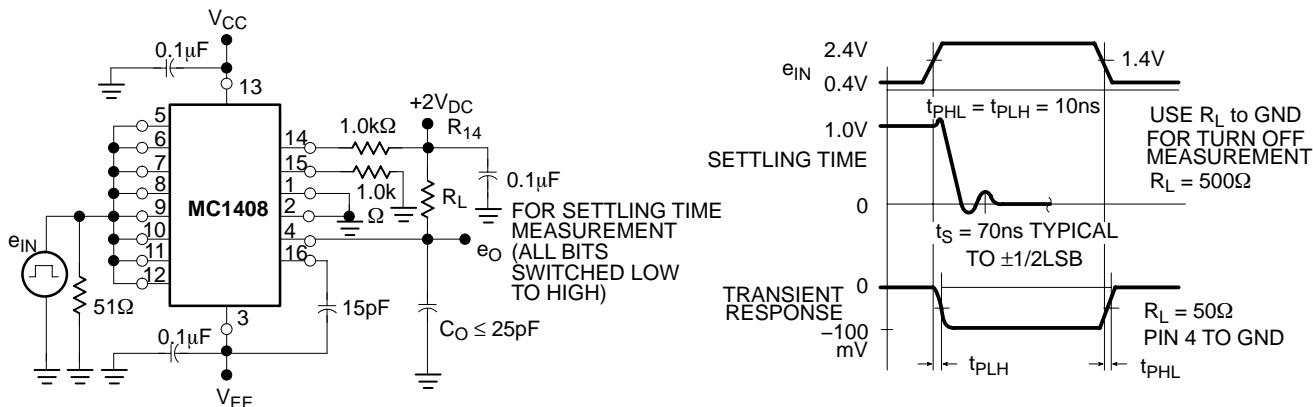

Figure 6. Transient Response and Settling Time

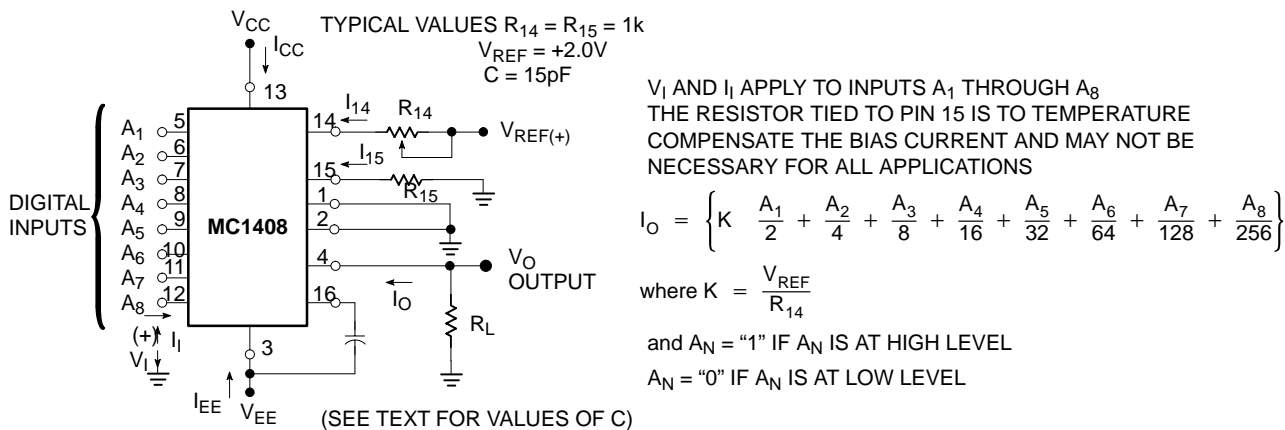

Figure 7. Notation Definitions



# MC1408-8

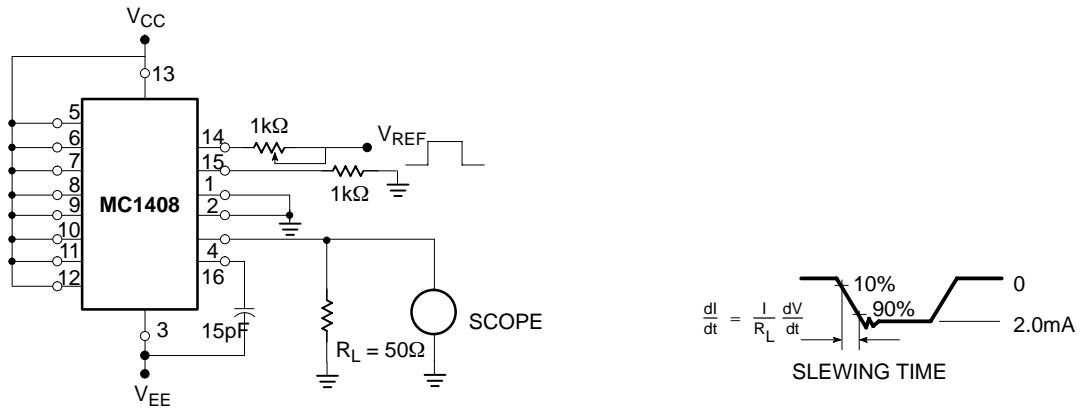

Figure 8. Reference Current Slew Rate Measurement

## ORDERING INFORMATION

Device	Temperature Range	Package	Shipping†
MC1408-8D	0°C to +70°C	SOIC-16	48 Units/Rail
MC1408-8DG		SOIC-16 (Pb-Free)	
MC1408-8DR2		SOIC-16	2500 Tape and Reel
MC1408-8DR2G		SOIC-16 (Pb-Free)	
MC1408-8N		PDIP-16	25 Units/Rail
MC1408-8NG		PDIP-16 (Pb-Free)	

†For information on tape and reel specifications, including part orientation and tape sizes, please refer to our Tape and Reel Packaging Specifications Brochure, BRD8011/D.

# MC1408-8

## PACKAGE DIMENSIONS

### PDIP-16 CASE 648-08 ISSUE T

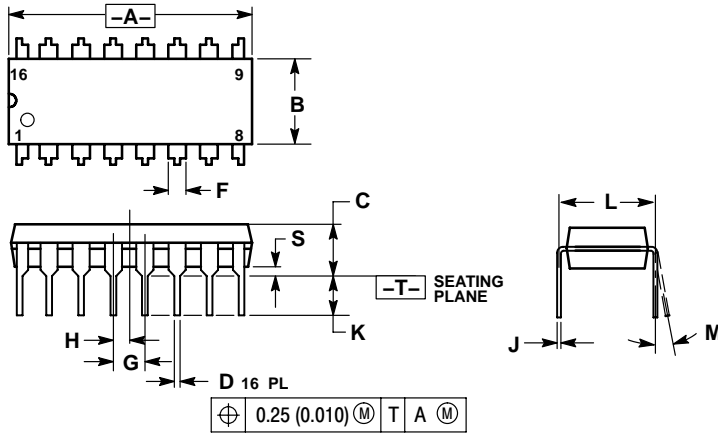

NOTES:

1. DIMENSIONING AND TOLERANCING PER ANSI Y14.5M, 1982.
2. CONTROLLING DIMENSION: INCH.
3. DIMENSION L TO CENTER OF LEADS WHEN FORMED PARALLEL.
4. DIMENSION B DOES NOT INCLUDE MOLD FLASH.
5. ROUNDED CORNERS OPTIONAL.

DIM	INCHES		MILLIMETERS	
	MIN	MAX	MIN	MAX
A	0.740	0.770	18.80	19.55
B	0.250	0.270	6.35	6.85
C	0.145	0.175	3.69	4.44
D	0.015	0.021	0.39	0.53
F	0.040	0.70	1.02	1.77
G	0.100 BSC		2.54 BSC	
H	0.050 BSC		1.27 BSC	
J	0.008	0.015	0.21	0.38
K	0.110	0.130	2.80	3.30
L	0.295	0.305	7.50	7.74
M	0°	10°	0°	10°
S	0.020	0.040	0.51	1.01

### SOIC-16 CASE 751B-05 ISSUE J

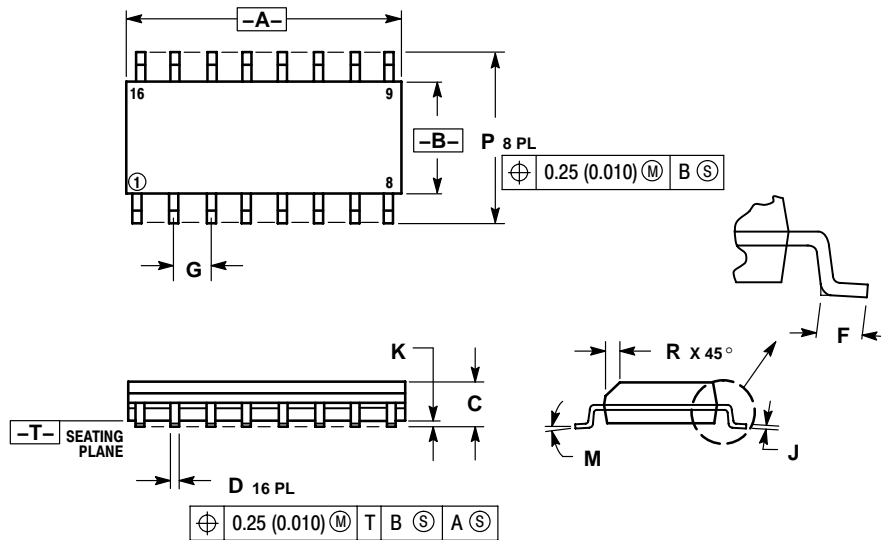

NOTES:

1. DIMENSIONING AND TOLERANCING PER ANSI Y14.5M, 1982.
2. CONTROLLING DIMENSION: MILLIMETER.
3. DIMENSIONS A AND B DO NOT INCLUDE MOLD PROTRUSION.
4. MAXIMUM MOLD PROTRUSION 0.15 (0.006) PER SIDE.
5. DIMENSION D DOES NOT INCLUDE DAMBAR PROTRUSION. ALLOWABLE DAMBAR PROTRUSION SHALL BE 0.127 (0.005) TOTAL IN EXCESS OF THE D DIMENSION AT MAXIMUM MATERIAL CONDITION.

DIM	MILLIMETERS		INCHES	
	MIN	MAX	MIN	MAX
A	9.80	10.00	0.386	0.393
B	3.80	4.00	0.150	0.157
C	1.35	1.75	0.054	0.068
D	0.35	0.49	0.014	0.019
F	0.40	1.25	0.016	0.049
G	1.27 BSC		0.050 BSC	
J	0.19	0.25	0.008	0.009
K	0.10	0.25	0.004	0.009
M	0°	7°	0°	7°
P	5.80	6.20	0.229	0.244
R	0.25	0.50	0.010	0.019

**ON Semiconductor** and **ON** are registered trademarks of Semiconductor Components Industries, LLC (SCILLC). SCILLC reserves the right to make changes without further notice to any products herein. SCILLC makes no warranty, representation or guarantee regarding the suitability of its products for any particular purpose, nor does SCILLC assume any liability arising out of the application or use of any product or circuit, and specifically disclaims any and all liability, including without limitation special, consequential or incidental damages. "Typical" parameters which may be provided in SCILLC data sheets and/or specifications can and do vary in different applications and actual performance may vary over time. All operating parameters, including "Typicals" must be validated for each customer application by customer's technical experts. SCILLC does not convey any license under its patent rights nor the rights of others. SCILLC products are not designed, intended, or authorized for use as components in systems intended for surgical implant into the body, or other applications intended to support or sustain life, or for any other application in which the failure of the SCILLC product could create a situation where personal injury or death may occur. Should Buyer purchase or use SCILLC products for any such unintended or unauthorized application, Buyer shall indemnify and hold SCILLC and its officers, employees, subsidiaries, affiliates, and distributors harmless against all claims, costs, damages, and expenses, and reasonable attorney fees arising out of, directly or indirectly, any claim of personal injury or death associated with such unintended or unauthorized use, even if such claim alleges that SCILLC was negligent regarding the design or manufacture of the part. SCILLC is an Equal Opportunity/Affirmative Action Employer. This literature is subject to all applicable copyright laws and is not for resale in any manner.

## PUBLICATION ORDERING INFORMATION

**LITERATURE FULFILLMENT:**

Literature Distribution Center for ON Semiconductor  
P.O. Box 5163, Denver, Colorado 80217 USA  
Phone: 303-675-2175 or 800-344-3860 Toll Free USA/Canada  
Fax: 303-675-2176 or 800-344-3867 Toll Free USA/Canada  
Email: orderlit@onsemi.com

**N. American Technical Support:** 800-282-9855 Toll Free USA/Canada  
**Europe, Middle East and Africa Technical Support:**  
Phone: 421 33 790 2910  
**Japan Customer Focus Center**  
Phone: 81-3-5773-3850

**ON Semiconductor Website:** [www.onsemi.com](http://www.onsemi.com)

**Order Literature:** <http://www.onsemi.com/orderlit>

For additional information, please contact your local Sales Representative