

# MC14517B

## Dual 64-Bit Static Shift Register

The MC14517B dual 64-bit static shift register consists of two identical, independent, 64-bit registers. Each register has separate clock and write enable inputs, as well as outputs at bits 16, 32, 48, and 64. Data at the data input is entered by clocking, regardless of the state of the write enable input. An output is disabled (open circuited) when the write enable input is high. During this time, data appearing at the data input as well as the 16-bit, 32-bit, and 48-bit taps may be entered into the device by application of a clock pulse. This feature permits the register to be loaded with 64 bits in 16 clock periods, and also permits bus logic to be used. This device is useful in time delay circuits, temporary memory storage circuits, and other serial shift register applications.

### Features

- Diode Protection on All Inputs
- Fully Static Operation
- Output Transitions Occur on the Rising Edge of the Clock Pulse
- Exceedingly Slow Input Transition Rates May Be Applied to the Clock Input
- 3-State Output at 64th-Bit Allows Use in Bus Logic Applications
- Shift Registers of any Length may be Fully Loaded with 16 Clock Pulses
- Supply Voltage Range = 3.0 Vdc to 18 Vdc
- Capable of Driving Two Low-Power TTL Loads or One Low-Power Schottky TTL Load Over the Rated Temperature Range
- NLV Prefix for Automotive and Other Applications Requiring Unique Site and Control Change Requirements; AEC-Q100 Qualified and PPAP Capable
- This Device is Pb-Free and is RoHS Compliant

### MAXIMUM RATINGS (Voltages Referenced to $V_{SS}$ )

Parameter	Symbol	Value	Unit
DC Supply Voltage Range	$V_{DD}$	-0.5 to +18.0	V
Input or Output Voltage Range (DC or Transient)	$V_{in}, V_{out}$	-0.5 to $V_{DD}$ + 0.5	V
Input or Output Current (DC or Transient) per Pin	$I_{in}, I_{out}$	±10	mA
Power Dissipation per Package (Note 1)	$P_D$	500	mW
Operating Temperature Range	$T_A$	-55 to +125	°C
Storage Temperature Range	$T_{stg}$	-65 to +150	°C
Lead Temperature (8-Second Soldering)	$T_L$	260	°C

Stresses exceeding those listed in the Maximum Ratings table may damage the device. If any of these limits are exceeded, device functionality should not be assumed, damage may occur and reliability may be affected.

1. Temperature Derating: Plastic "D/DW" Package: -7.0 mW/°C From 65°C to 125°C

This device contains protection circuitry to guard against damage due to high static voltages or electric fields. However, precautions must be taken to avoid applications of any voltage higher than maximum rated voltages to this high-impedance circuit. For proper operation,  $V_{in}$  and  $V_{out}$  should be constrained to the range  $V_{SS} \leq (V_{in} \text{ or } V_{out}) \leq V_{DD}$ .

Unused inputs must always be tied to an appropriate logic voltage level (e.g., either  $V_{SS}$  or  $V_{DD}$ ). Unused outputs must be left open.



ON Semiconductor®

<http://onsemi.com>

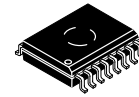

1  
SOIC-16 WB  
DW SUFFIX  
CASE 751G

### MARKING DIAGRAM

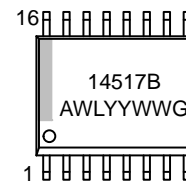

A = Assembly Location  
WL, L = Wafer Lot  
YY, Y = Year  
WW, W = Work Week  
G = Pb-Free Package

### PIN ASSIGNMENT

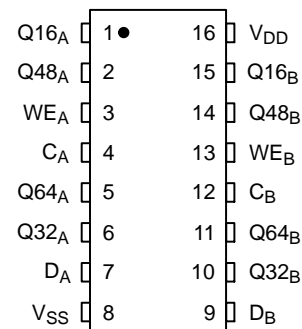

### ORDERING INFORMATION

Device	Package	Shipping†
MC14517BDWG	SOIC-16 WB (Pb-Free)	47 Units/Rail
MC14517BDWR2G	SOIC-16 WB (Pb-Free)	1000 / Tape & Reel
NLV14517BDWR2G	SOIC-16 WB (Pb-Free)	1000 / Tape & Reel

†For information on tape and reel specifications, including part orientation and tape sizes, please refer to our Tape and Reel Packaging Specifications Brochure, BRD8011/D.

# MC14517B

**FUNCTIONAL TRUTH TABLE** (X = Don't Care)

Clock	Write Enable	Data	16-Bit Tap	32-Bit Tap	48-Bit Tap	64-Bit Tap
0	0	X	Content of 16-Bit Displayed	Content of 32-Bit Displayed	Content of 48-Bit Displayed	Content of 64-Bit Displayed
0	1	X	High Impedance	High Impedance	High Impedance	High Impedance
1	0	X	Content of 16-Bit Displayed	Content of 32-Bit Displayed	Content of 48-Bit Displayed	Content of 64-Bit Displayed
1	1	X	High Impedance	High Impedance	High Impedance	High Impedance
	0	Data entered into 1st Bit	Content of 16-Bit Displayed	Content of 32-Bit Displayed	Content of 48-Bit Displayed	Content of 64-Bit Displayed
	1	Data entered into 1st Bit	Data at tap entered into 17-Bit	Data at tap entered into 33-Bit	Data at tap entered into 49-Bit	High Impedance
	0	X	Content of 16-Bit Displayed	Content of 32-Bit Displayed	Content of 48-Bit Displayed	Content of 64-Bit Displayed
	1	X	High Impedance	High Impedance	High Impedance	High Impedance

**ELECTRICAL CHARACTERISTICS** (Voltages Referenced to  $V_{SS}$ )

Characteristic	Symbol	$V_{DD}$ Vdc	- 55°C		25°C			125°C		Unit	
			Min	Max	Min	Typ (Note 2)	Max	Min	Max		
Output Voltage $V_{in} = V_{DD}$ or 0  $V_{in} = 0$ or $V_{DD}$	"0" Level  "1" Level	$V_{OL}$	5.0	-	0.05	-	0	0.05	-	0.05	Vdc
			10	-	0.05	-	0	0.05	-	0.05	
		$V_{OH}$	5.0	4.95	-	4.95	5.0	-	4.95	-	Vdc
			10	9.95	-	9.95	10	-	9.95	-	
Input Voltage ( $V_O = 4.5$ or $0.5$ Vdc) ( $V_O = 9.0$ or $1.0$ Vdc) ( $V_O = 13.5$ or $1.5$ Vdc)	"0" Level	$V_{IL}$	5.0	-	1.5	-	2.25	1.5	-	1.5	Vdc
			10	-	3.0	-	4.50	3.0	-	3.0	
	"1" Level	$V_{IH}$	5.0	3.5	-	3.5	2.75	-	3.5	-	Vdc
			10	7.0	-	7.0	5.50	-	7.0	-	
Output Drive Current ( $V_{OH} = 2.5$ Vdc) ( $V_{OH} = 4.6$ Vdc) ( $V_{OH} = 9.5$ Vdc) ( $V_{OH} = 13.5$ Vdc)  ( $V_{OL} = 0.4$ Vdc) ( $V_{OL} = 0.5$ Vdc) ( $V_{OL} = 1.5$ Vdc)	Source	$I_{OH}$	5.0	-3.0	-	-2.4	-4.2	-	-1.7	-	mAdc
			5.0	-0.64	-	-0.51	-0.88	-	-0.36	-	
	Sink	$I_{OL}$	10	-1.6	-	-1.3	-2.25	-	-0.9	-	mAdc
			15	-4.2	-	-3.4	-8.8	-	-2.4	-	
Input Current		$I_{in}$	15	-	$\pm 0.1$	-	$\pm 0.00001$	$\pm 0.1$	-	$\pm 1.0$	$\mu$ Adc
Input Capacitance ( $V_{in} = 0$ )		$C_{in}$	-	-	-	-	5.0	7.5	-	-	pF
Quiescent Current (Per Package)		$I_{DD}$	5.0	-	5.0	-	0.005	5.0	-	150	$\mu$ Adc
			10	-	10	-	0.010	10	-	300	
			15	-	20	-	0.015	20	-	600	
Total Supply Current (Note 3, 4) (Dynamic plus Quiescent, Per Package) ( $C_L = 50$ pF on all outputs, all buffers switching)		$I_T$	5.0	$I_T = (4.2 \mu A/kHz) f + I_{DD}$						$\mu$ Adc	
		10	$I_T = (8.8 \mu A/kHz) f + I_{DD}$								
		15	$I_T = (13.7 \mu A/kHz) f + I_{DD}$								
Three-State Leakage Current		$I_{TL}$	15	-	$\pm 0.1$	-	$\pm 0.0001$	$\pm 0.1$	-	$\pm 3.0$	$\mu$ Adc

Product parametric performance is indicated in the Electrical Characteristics for the listed test conditions, unless otherwise noted. Product performance may not be indicated by the Electrical Characteristics if operated under different conditions.

2. Data labelled "Typ" is not to be used for design purposes but is intended as an indication of the IC's potential performance.

3. The formulas given are for the typical characteristics only at 25°C.

4. To calculate total supply current at loads other than 50 pF:  $I_T(C_L) = I_T(50 \text{ pF}) + (C_L - 50) V f k$  where:  $I_T$  is in  $\mu A$  (per package),  $C_L$  in pF,  $V = (V_{DD} - V_{SS})$  in volts,  $f$  in kHz is input frequency, and  $k = 0.004$ .

# MC14517B

## SWITCHING CHARACTERISTICS (Note 5) ( $C_L = 50 \text{ pF}$ , $T_A = 25^\circ\text{C}$ )

Characteristic	Symbol	$V_{DD}$	Min	Typ (Note 6)	Max	Unit
Output Rise and Fall Time $t_{TLH}$ , $t_{THL} = (1.5 \text{ ns/pF}) C_L + 25 \text{ ns}$ $t_{TLH}$ , $t_{THL} = (0.75 \text{ ns/pF}) C_L + 12.5 \text{ ns}$ $t_{TLH}$ , $t_{THL} = (0.65 \text{ ns/pF}) C_L + 9.5 \text{ ns}$	$t_{TLH}$ , $t_{THL}$	5.0 10 15	– – –	100 50 40	200 100 80	ns
Propagation Delay Time $t_{PLH}$ , $t_{PHL} = (1.7 \text{ ns/pF}) C_L + 390 \text{ ns}$ $t_{PLH}$ , $t_{PHL} = (0.66 \text{ ns/pF}) C_L + 177 \text{ ns}$ $t_{PLH}$ , $t_{PHL} = (0.5 \text{ ns/pF}) C_L + 115 \text{ ns}$	$t_{PLH}$ , $t_{PHL}$	5.0 10 15	– – –	475 210 140	770 300 215	ns
Clock Pulse Width	$t_{WH}$	5.0 10 15	330 125 100	170 75 60	– – –	ns
Clock Pulse Frequency	$f_{cl}$	5.0 10 15	– – –	3.0 6.7 8.3	1.5 4.0 5.3	MHz
Clock Pulse Rise and Fall Time	$t_{TLH}$ , $t_{THL}$	5.0 10 15	See (Note 7)			–
Data to Clock Setup Time	$t_{su}$	5.0 10 15	0 10 15	–40 –15 0	– – –	ns
Data to Clock Hold Time	$t_h$	5.0 10 15	150 75 35	75 25 10	– – –	ns
Write Enable to Clock Setup Time	$t_{su}$	5.0 10 15	400 200 110	170 65 50	– – –	ns
Write Enable to Clock Release Time	$t_{rel}$	5.0 10 15	380 180 100	160 55 40	– – –	ns

- The formulas given are for the typical characteristics only at  $25^\circ\text{C}$ .
- Data labelled "Typ" is not to be used for design purposes but is intended as an indication of the IC's potential performance.
- When shift register sections are cascaded, the maximum rise and fall time of the clock input should be equal to or less than the rise and fall time of the data outputs, driving data inputs, plus the propagation delay of the output driving stage.

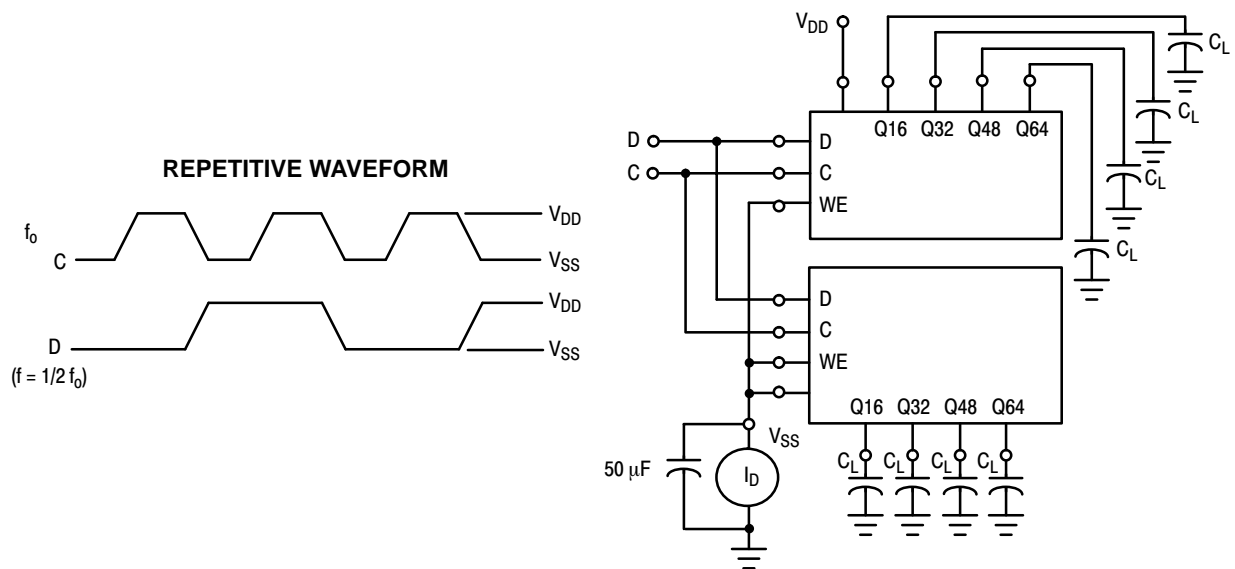
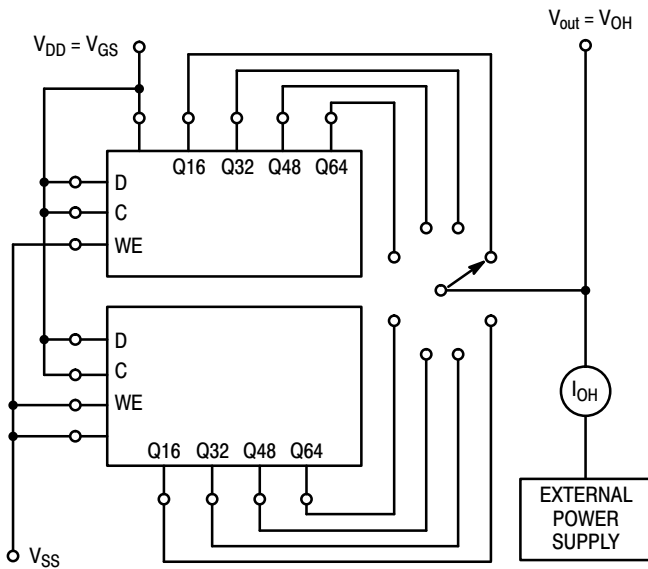

Figure 1. Power Dissipation Test Circuit and Waveform

# MC14517B



(Output being tested should be in the high-logic state)

**Figure 2. Typical Output Source Current Characteristics Test Circuit**

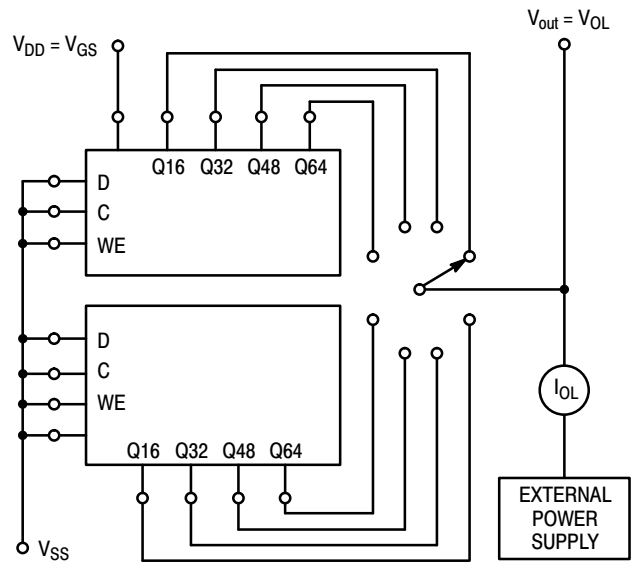

(Output being tested should be in the low-logic state)

**Figure 3. Typical Output Sink Current Characteristics Test Circuit**

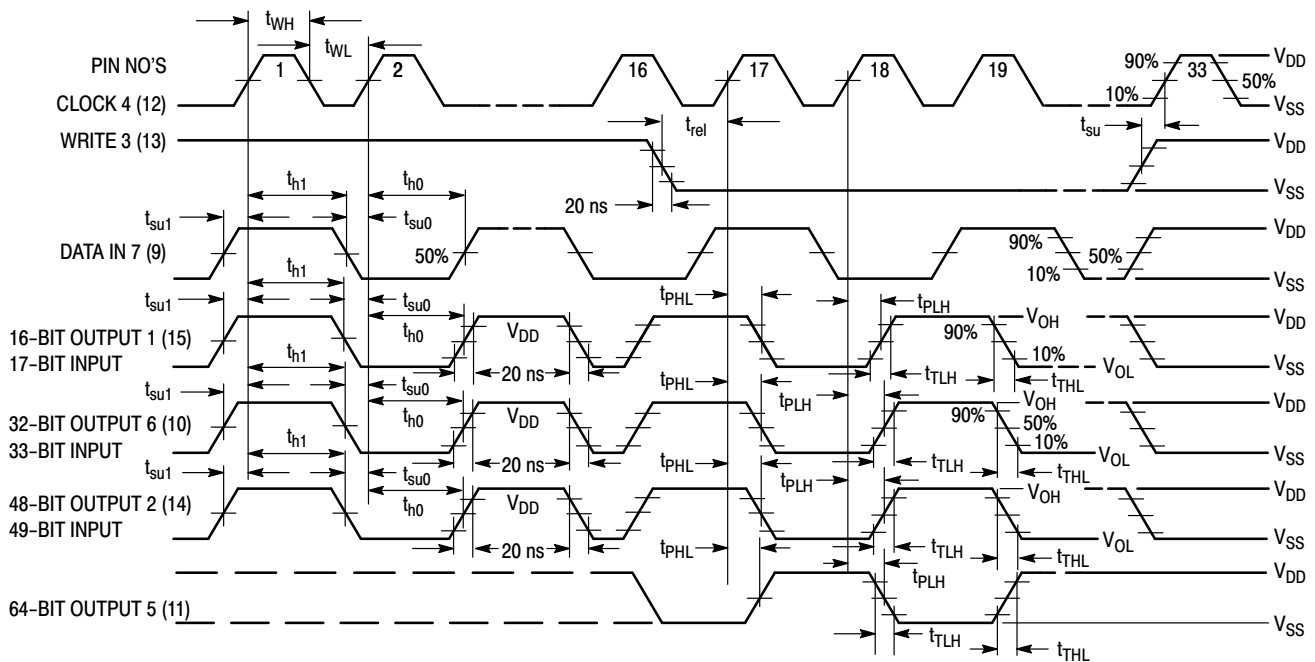

**Figure 4. AC Test Waveforms**

## EXPANDED BLOCK DIAGRAM (1/2 OF DEVICE SHOWN)

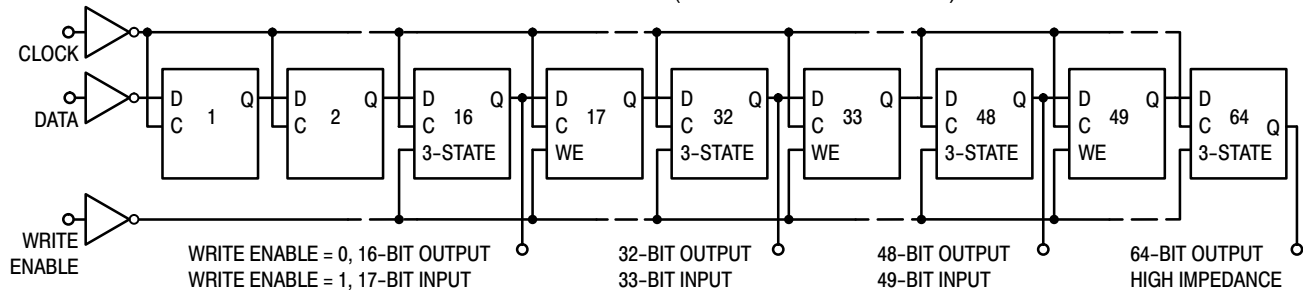

# MECHANICAL CASE OUTLINE PACKAGE DIMENSIONS



1  
SCALE 1:1

SOIC-16 WB  
CASE 751G  
ISSUE E

DATE 08 OCT 2021

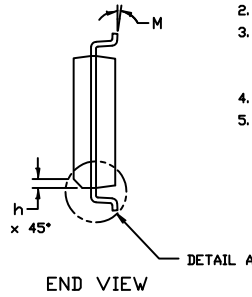
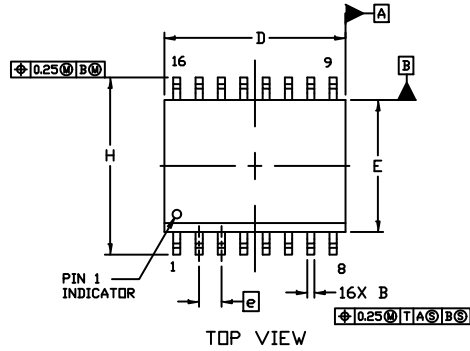

NOTES:

- DIMENSIONING AND TOLERANCING PER ASME Y14.5M, 1994.
- CONTROLLING DIMENSION: MILLIMETERS
- DIMENSION *b* DOES NOT INCLUDE DAMBAR PROTRUSION. ALLOWABLE PROTRUSION SHALL BE 0.13 TOTAL IN EXCESS OF *B* DIMENSION AT MAXIMUM MATERIAL CONDITION.
- DIMENSIONS *D* AND *E* DO NOT INCLUDE MOLD PROTRUSIONS.
- MAXIMUM MOLD PROTRUSION OR FLASH TO BE 0.15 PER SIDE.

DIM	MILLIMETERS	
	MIN.	MAX.
A	2.35	2.65
A1	0.10	0.25
B	0.35	0.49
C	0.23	0.32
D	10.15	10.45
E	7.40	7.60
e	1.27 BSC	
H	10.05	10.55
h	0.53 REF	
L	0.50	0.90
M	0°	7°

GENERIC MARKING DIAGRAM\*



- XXXXX = Specific Device Code
- A = Assembly Location
- WL = Wafer Lot
- YY = Year
- WW = Work Week
- G = Pb-Free Package

\*This information is generic. Please refer to device data sheet for actual part marking. Pb-Free indicator, "G" or microdot "▪", may or may not be present. Some products may not follow the Generic Marking.



DOCUMENT NUMBER:	98ASB42567B	Electronic versions are uncontrolled except when accessed directly from the Document Repository. Printed versions are uncontrolled except when stamped "CONTROLLED COPY" in red.
DESCRIPTION:	SOIC-16 WB	PAGE 1 OF 1

onsemi and onsemi are trademarks of Semiconductor Components Industries, LLC dba onsemi or its subsidiaries in the United States and/or other countries. onsemi reserves the right to make changes without further notice to any products herein. onsemi makes no warranty, representation or guarantee regarding the suitability of its products for any particular purpose, nor does onsemi assume any liability arising out of the application or use of any product or circuit, and specifically disclaims any and all liability, including without limitation special, consequential or incidental damages. onsemi does not convey any license under its patent rights nor the rights of others.

**onsemi**, **Onsemi**, and other names, marks, and brands are registered and/or common law trademarks of Semiconductor Components Industries, LLC dba "**onsemi**" or its affiliates and/or subsidiaries in the United States and/or other countries. **onsemi** owns the rights to a number of patents, trademarks, copyrights, trade secrets, and other intellectual property. A listing of **onsemi**'s product/patent coverage may be accessed at [www.onsemi.com/site/pdf/Patent-Marking.pdf](http://www.onsemi.com/site/pdf/Patent-Marking.pdf). **onsemi** reserves the right to make changes at any time to any products or information herein, without notice. The information herein is provided "as-is" and **onsemi** makes no warranty, representation or guarantee regarding the accuracy of the information, product features, availability, functionality, or suitability of its products for any particular purpose, nor does **onsemi** assume any liability arising out of the application or use of any product or circuit, and specifically disclaims any and all liability, including without limitation special, consequential or incidental damages. Buyer is responsible for its products and applications using **onsemi** products, including compliance with all laws, regulations and safety requirements or standards, regardless of any support or applications information provided by **onsemi**. "Typical" parameters which may be provided in **onsemi** data sheets and/or specifications can and do vary in different applications and actual performance may vary over time. All operating parameters, including "Typicals" must be validated for each customer application by customer's technical experts. **onsemi** does not convey any license under any of its intellectual property rights nor the rights of others. **onsemi** products are not designed, intended, or authorized for use as a critical component in life support systems or any FDA Class 3 medical devices or medical devices with a same or similar classification in a foreign jurisdiction or any devices intended for implantation in the human body. Should Buyer purchase or use **onsemi** products for any such unintended or unauthorized application, Buyer shall indemnify and hold **onsemi** and its officers, employees, subsidiaries, affiliates, and distributors harmless against all claims, costs, damages, and expenses, and reasonable attorney fees arising out of, directly or indirectly, any claim of personal injury or death associated with such unintended or unauthorized use, even if such claim alleges that **onsemi** was negligent regarding the design or manufacture of the part. **onsemi** is an Equal Opportunity/Affirmative Action Employer. This literature is subject to all applicable copyright laws and is not for resale in any manner.

## ADDITIONAL INFORMATION

### TECHNICAL PUBLICATIONS:

Technical Library: [www.onsemi.com/design/resources/technical-documentation](http://www.onsemi.com/design/resources/technical-documentation)  
onsemi Website: [www.onsemi.com](http://www.onsemi.com)

### ONLINE SUPPORT: [www.onsemi.com/support](http://www.onsemi.com/support)

For additional information, please contact your local Sales Representative at [www.onsemi.com/support/sales](http://www.onsemi.com/support/sales)